

Service instructions for contractors

VIESMANN

Vitocrossal 300

Type CU3A, 13 to 60 kW

Gas condensing boiler with Matrix gas burner
and Lambda Pro Control,
Natural gas and LPG version

Open flue and room sealed operation



VITOCROSSAL 300



Safety instructions

-  Please follow these safety instructions closely to prevent accidents and material losses.

Safety instructions explained

-  **Danger**
This symbol warns against the risk of injury.

Note
Details identified by the word "Note" contain additional information.

-  **Please note**
This symbol warns against the risk of material losses and environmental pollution.

Target group

These instructions are exclusively intended for qualified contractors.

- Work on gas installations may only be carried out by a registered gas fitter.
- Work on electrical equipment may only be carried out by a qualified electrician.
- The system must be commissioned by the system installer or a qualified person authorised by the installer.

Regulations to be observed

- National installation regulations
- Statutory regulations for the prevention of accidents
- Statutory regulations for environmental protection
- Codes of practice of the relevant trade associations
- Relevant country-specific safety regulations

Safety instructions for working on the system

Working on the system

- Where gas is used as the fuel, close the main gas shut-off valve and safeguard it against unintentional reopening.
- Isolate the system from the power supply, e.g. by removing the separate fuse or by means of a mains isolator, and check that it is no longer live.
- Safeguard the system against reconnection.
- Wear suitable personal protective equipment when carrying out any work.

Safety instructions (cont.)**Danger**

Hot surfaces and fluids can lead to burns or scalding.

- Before maintenance and service work, switch OFF the appliance and let it cool down.
- Never touch hot surfaces on the boiler, burner, flue system or pipe-work.

**Please note**

Electronic assemblies can be damaged by electrostatic discharge. Prior to commencing work, touch earthed objects such as heating or water pipes to discharge static loads.

Auxiliary components, spare and wearing parts**Please note**

Auxiliary components, spare parts and wearing parts that have not been tested together with the system can compromise its function. Installing non-authorised components and making non-approved modifications or conversions can compromise safety and may invalidate our warranty. For installation and replacements, use only Viessmann original parts or parts approved by Viessmann.

Repair work**Please note**

Repairing components that fulfil a safety function can compromise the safe operation of the system. Replace faulty components only with genuine Viessmann spare parts.



Safety instructions for operating the system

If you smell gas

-  **Danger**
Escaping gas can lead to explosions which may result in serious injury.
- Do not smoke. Prevent naked flames and sparks. Never switch lights or electrical appliances on or off.
 - Close the gas shut-off valve.
 - Open windows and doors.
 - Evacuate any people from the danger zone.
 - Notify your gas or electricity supply utility from outside the building.
 - Have the power supply to the building shut off from a safe place (outside the building).

If you smell flue gas

-  **Danger**
Flue gas can lead to life threatening poisoning.
- Shut down the heating system.
 - Ventilate the installation site.
 - Close doors to living spaces to prevent flue gases from spreading.

What to do if water escapes from the appliance

-  **Danger**
If water escapes from the appliance there is a risk of electrocution. Switch OFF the heating system at the external isolator (e.g. fuse box, domestic distribution board).

-  **Danger**
If water escapes from the appliance there is a risk of scalding. Never touch hot heating water.

Condensate

-  **Danger**
Contact with condensate can be harmful to health. Never let condensate touch your skin or eyes and do not swallow it.

Flue systems and combustion air

Ensure that flue systems are clear and cannot be sealed, for instance due to accumulation of condensate or other external causes. Ensure an adequate supply of combustion air. Inform system users that subsequent modifications to the building characteristics are not permissible (e.g. cable/pipe-work routing, cladding or partitions).

-  **Danger**
Leaking or blocked flue systems, or an inadequate supply of combustion air can cause life threatening poisoning from carbon monoxide in the flue gas. Ensure the flue system is in good working order. Vents for supplying combustion air must be non-sealable.

Extractors

Operating appliances that extract air to the outside (extractor hoods, extractors, air conditioning units, central vacuum cleaning systems, etc.) can create negative pressure. If the boiler is operated at the same time, this can lead to a reverse flow of flue gas.

Safety instructions (cont.)**Danger**

The simultaneous operation of the boiler and appliances that exhausts air to the outside can result in life threatening poisoning due to a reverse flow of flue gas.

Fit an interlock circuit or take suitable steps to ensure an adequate supply of combustion air.



Index

1. Information	Symbols	9
	Intended use	9
	Product information	10
	■ System examples	10
	■ Maintenance parts and spare parts	10
2. Commissioning, inspection, maintenance	Steps - commissioning, inspection and maintenance	11
3. Code 1	Calling up coding level 1	32
	General	32
	Boiler	33
	DHW	34
	Solar	34
	Heating circuit 1, heating circuit 2, heating circuit 3	36
4. Code 2	Calling up coding level 2	39
	General	39
	Boiler	44
	DHW	44
	Solar	45
	Heating circuit 1, heating circuit 2, heating circuit 3	49
5. Diagnosis and service checks	Calling up the service menu	54
	Diagnosis	54
	■ Checking operating data	54
	■ Brief scan	54
	Checking outputs (actuator test)	55
6. Troubleshooting	Fault display	57
	Fault codes	57
	■ 10	57
	■ 18	57
	■ 19	58
	■ 30	58
	■ 38	58
	■ 40	58
	■ 44	58
	■ 48	58
	■ 4C	59
	■ 50	59
	■ 58	59
	■ 90	59
	■ 91	59
	■ 92	60
	■ 93	60
	■ 94	60
	■ 98	60
	■ 99	60
	■ 9A	60
	■ 9b	61
	■ 9C	61
	■ 9E	61
	■ 9F	61
	■ A3	61
	■ A7	62
	■ b0	62
	■ b1	62
	■ b5	62
	■ b7	62

■ b8	62
■ bA	63
■ bb	63
■ bC	63
■ bd	63
■ bE	63
■ bF	64
■ C1	64
■ C2	64
■ C3	64
■ Cd	64
■ CF	65
■ d6	65
■ d7	65
■ d8	65
■ dA	65
■ db	65
■ dC	66
■ dd	66
■ dE	66
■ dF	66
■ E0	66
■ E1	67
■ E3	67
■ E4	67
■ E5	67
■ E7	67
■ E8	68
■ EA	68
■ Eb	68
■ EC	68
■ Ed	68
■ EE	69
■ EF	69
■ F0	69
■ F1	69
■ F2	69
■ F3	70
■ F8	70
■ F9	70
■ FA	70
■ FC	70
■ Fd	71
■ Fd	71
■ FE	71
■ FF	71
■ OF	71

7. Maintenance











Checking the outside temperature sensor	72
Checking the cylinder temperature sensor	73
Checking boiler water temperature sensor	73
Checking the flue gas temperature sensor	74
Fault during commissioning (fault A3)	75
Checking the temperature limiter	75
Checking the fuse	76
Mixer extension kit	76
Checking the Vitotronic 200-H (accessories)	77

8. Function description







Weather-compensated control unit	78
■ Heating mode	78

	■ DHW heating	78
	■ Boosting DHW heating	78
	Connecting the Vitoconnect 100 connecting cable (accessories)	79
	■ Installing the Vitoconnect 100	79
	Internal extensions (accessories)	80
	■ Internal H1 extension	80
	■ Internal H2 extension	81
	External extension (accessories)	82
	■ EA1 extension	82
	Control functions	83
	■ External operating program changeover	83
	■ External blocking	84
	■ External demand	85
	■ Screed drying	85
	■ Raising the reduced room temperature	87
	■ Reducing the heat-up time	87
	Assigning heating circuits to the remote control	88
	Electronic combustion control unit	88
9. Connection diagram	Internal connection diagram	90
	External connection diagram	92
10. Water quality	Requirements	93
11. Commissioning/service reports	95
	Settings and test values	96
12. Specification	97
13. Shutdown and disposal	Final decommissioning and disposal	98
14. Certificates	Declaration of conformity	99
	Manufacturer's certificate according to the 1st BImSchV [Germany]	99
15. Keyword index	100

Symbols

Symbol	Meaning
	Reference to other document containing further information
	Step in a diagram: The numbers correspond to the order in which the steps are carried out.
	Warning of personal injury
	Warning of material losses and environmental pollution
	Live electrical area
	Pay particular attention.
	<ul style="list-style-type: none"> ▪ Component must audibly click into place. or ▪ Acoustic signal
	<ul style="list-style-type: none"> ▪ Fit new component. or ▪ In conjunction with a tool: Clean the surface.
	Dispose of component correctly.
	Dispose of component at a suitable collection point. Do not dispose of component in domestic waste.

The steps in connection with commissioning, inspection and maintenance are found in the "Commissioning, inspection and maintenance" section and identified as follows:

Symbol	Meaning
	Steps required during commissioning
	Not required during commissioning
	Steps required during inspection
	Not required during inspection
	Steps required during maintenance
	Not required during maintenance

Intended use

The appliance is intended solely for installation and operation in sealed unvented heating systems that comply with EN 12828, with due attention paid to CECS 215-2017 and the associated installation, service and operating instructions. It is only designed for heating up heating water that is of potable water quality.

Intended use presupposes that a fixed installation in conjunction with permissible, system-specific components has been carried out.

The appliance is intended exclusively for domestic or semi-domestic use; even users who have not had any instruction are able to operate the appliance safely.

Commercial or industrial usage for a purpose other than heating the building or DHW shall be deemed inappropriate.

Any usage beyond this must be approved by the manufacturer in each individual case.

Intended use (cont.)

Incorrect usage or operation of the appliance (e.g. the appliance being opened by the system user) is prohibited and will result in an exclusion of liability. Incorrect usage also occurs if the components in the heating system are modified from their intended use (e.g. if the flue gas and ventilation air paths are sealed).

Product information

Vitocrossal 300, CU3A

Preset for operation with natural gas E and LL

Conversion to LPG P



See service instructions.

Conversion for other countries

The Vitocrossal 300 may only be delivered to the countries specified on the type plate. For deliveries to other countries, approved contractors must arrange individual approval on their own initiative and in accordance with the law of the country in question.

System examples

Available system examples:
www.viessmann-schemes.com



Maintenance parts and spare parts

Maintenance parts and spare parts can be identified and ordered directly online.

Viessmann Partnership

Login:
<https://shop.viessmann.com/>



Viessmann spare part app

www.viessmann.com/etapp





Steps - commissioning, inspection and maintenance

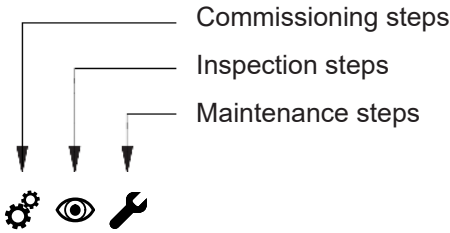

Page

•		1. Filling the heating system and checking the supply of ventilation air.....	12
•		2. Checking the power supply	
•		3. Changing the language (if required).....	12
•	•	4. Setting the time and date (if required).....	13
•		5. Naming the heating circuits.....	13
•	•	6. Checking the gas type.....	13
•	•	7. Removing the front panel.....	14
•		8. Converting the gas type (only for operation with LPG).....	15
•	•	9. Function sequence and possible faults.....	15
•	•	10. Testing the static and supply pressure.....	16
•		11. Setting the maximum heating output.....	17
•		12. Checking the balanced flue system for leaks (annular gap test).....	18
	•	13. Removing the burner and checking the burner gasket.....	19
	•	14. Checking the burner gauze assembly and thermal insulation block.....	20
	•	15. Checking and adjusting the ignition and ionisation electrodes.....	21
	•	16. Separating the neutralising system (if installed) from the boiler and connecting the drain hose.....	22
	•	17. Cleaning the combustion chamber and heating surfaces.....	22
	•	18. Cleaning and reconnecting the condensate drain system.....	22
	•	19. Checking the condensate drain and neutralising system (if installed) for obstructions and leaks.....	23
	•	20. Checking the gaskets and thermal insulation parts on the boiler side.....	24
	•	21. Checking the expansion vessel and system pressure.....	24
	•	22. Checking the water quality.....	25
	•	23. Checking the mixer for ease of operation and leaks.....	25
	•	24. Checking all connections on the heating water and DHW sides for leaks	
	•	25. Checking the safety valve function	
	•	26. Installing the burner.....	26
	•	27. Checking the firm seating of electrical connections	
	•	28. Checking all gas equipment for leaks at operating pressure.....	27
	•	29. Checking the combustion quality.....	27
	•	30. Checking the ventilation air apertures in the installation room (open flue operation)	
	•	31. Checking the external LPG safety valve (if installed)	
	•	32. Matching the control unit to the heating system.....	28
	•	33. Adjusting the heating curves.....	28
	•	34. Connecting the control unit to the LON.....	29
	•	35. Checking and resetting the "Service" display.....	30
	•	36. Mounting the front panel.....	31
	•	37. Instructing the system user.....	31





Filling the heating system and checking the supply of ventilation air

! Please note
 Unsuitable fill water increases the level of deposits and corrosion. It can lead to boiler damage.
 Only use suitable fill water.

- Flush the heating system thoroughly before filling.
- For water quality requirement, see page 93.
- Only use fill water of potable water quality.
- Soften fill water with a water hardness above 16.8 °dH (3.0 mol/m³), e.g. with the small softening system for heating water.



Vitaset pricelist

- Special antifreeze suitable for heating systems can be added to the fill water. The antifreeze manufacturer must verify its suitability, as damage to gaskets or diaphragms and noise during heating operation may otherwise occur.
 Viessmann accepts no liability for any resulting damage or consequential losses.

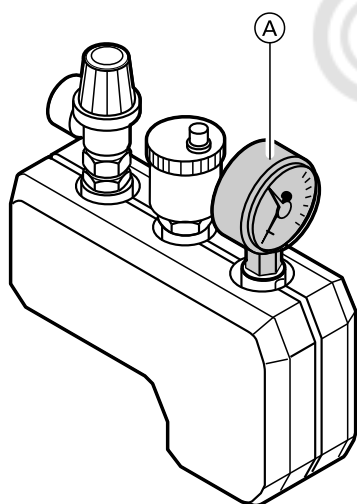

Fig. 1

1. Check whether the ventilation air supply is unrestricted.
2. Check the pre-charge pressure of the expansion vessel when the system is still cold.

Note

If the pre-charge pressure of the expansion vessel is lower than the static system pressure, top up with nitrogen until the pre-charge pressure is 0.1 to 0.2 bar (10 to 20 kPa) higher than the static system pressure. The static pressure corresponds to the static head.

3. Open any installed check valves.
4. Fill the heating system with water and vent until the charge pressure is 0.1 to 0.2 bar (10 to 20 kPa) higher than the pre-charge pressure of the expansion vessel.
 Permiss. operating pressure: 3 bar (0.3 MPa)
 Minimum operating pressure: 0.5 bar (50 kPa)

Note

The minimum operating pressure is essential for safe operation. It can be ensured with a minimum pressure switch (one per system for multi boiler systems).

5. Mark the set pressure on pressure gauge (A).
6. Record the amount of fill water, water hardness and pH value on page 95.

Note

Observe the "Water quality requirements" on page 93.

7. Return the check valves to their operating position.



Checking the power supply



Changing the language (if required)

At the commissioning stage, the display is in German (factory setting).

Extended menu:

1. ☰
2. "Settings"
3. "Language"

4. Set the required language with ▲/▼.





Changing the language (if required) (cont.)

Fig. 2



Setting the time and date (if required)

The time and date need to be reset during commissioning or after a prolonged time out of use (approx. 18 days).

1. 
2. "Settings"
3. "Time / Date"

4. Set current time and date.

Note

When time and date have been set, the control unit automatically checks the function of the flue gas temperature sensor. The display shows: "**Test, flue gas temp. sensor**" and "**Active**". See page 75.



Naming the heating circuits

In the delivered condition, the heating circuits are designated "**Heating circuit 1**", "**Heating circuit 2**", "**Heating circuit ...**" (if installed).

If the system user prefers, the heating circuits can be renamed to suit the specific system.



To enter names for heating circuits:
Operating instructions



Checking the gas type

The boiler is equipped with an electronic combustion controller that adjusts the burner for optimum combustion in accordance with the prevailing gas quality.

- Operation with natural gas therefore requires no adjustment across the entire Wobbe index range. The boiler can be operated within the Wobbe index range 9.5 to 15.2 kWh/m³ (34.2 to 54.7 MJ/m³).
- For operation with LPG, the burner must be converted (see "Converting the gas type" on page 15).

1. Determine the gas type and Wobbe index by asking your local gas supply utility or LPG supplier.
2. For operation with LPG, convert the burner (see page 15).
3. Record the gas type in the report on page 96.



Removing the front panel

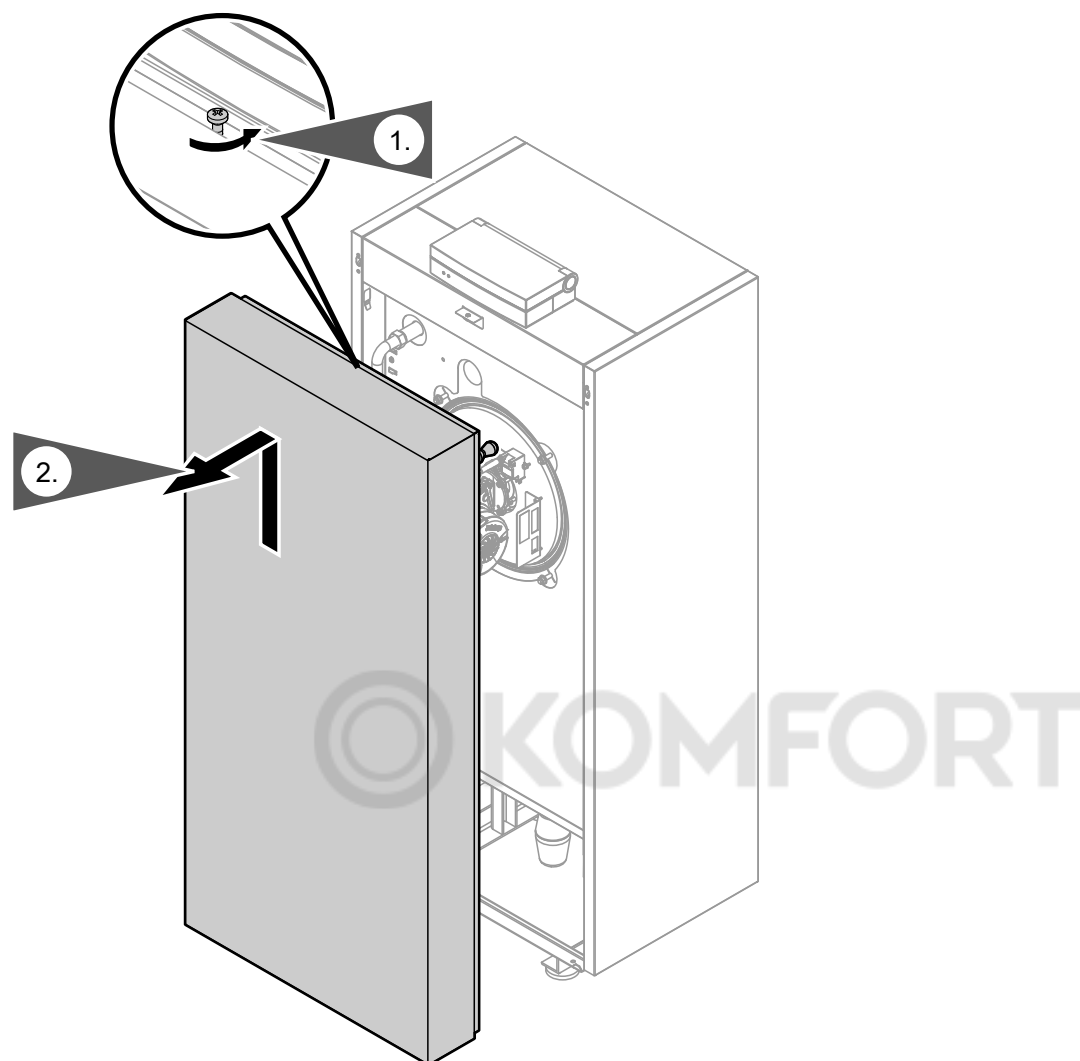

Fig. 3



Converting the gas type (only for operation with LPG)

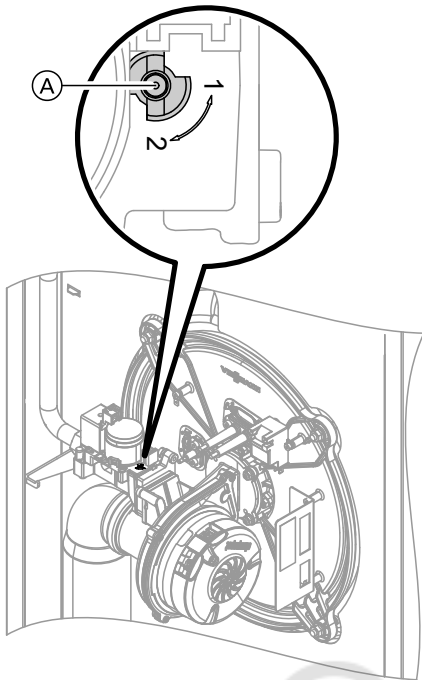
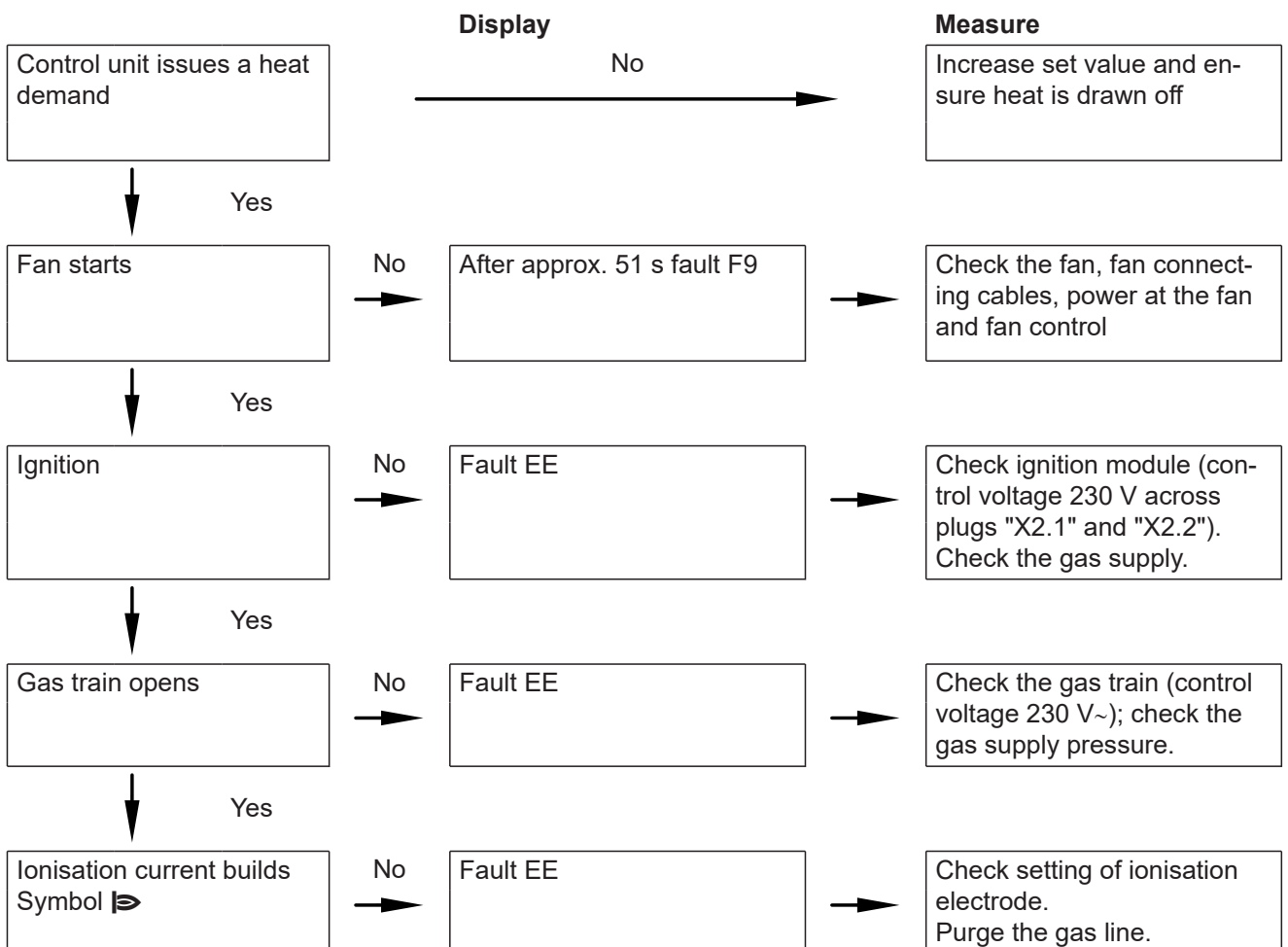

Fig. 4

1. Set adjusting screw (A) on the gas solenoid valve to "2".
2. Turn on the ON/OFF switch (B).
3. Select the gas type in coding address "82":
 - Call up code 2.
 - **"General"**
 - In coding address "11", select value "9".
 - In coding address "82", select value "1" (operation with LPG).
 - Set code "11" value not equal to "9".
 - Confirm with OK. The display shows "11:0"
 - End service functions.
4. Open the gas shut-off valve.
5. Affix label "G31" (supplied with the technical documentation) below the type plate on the side panel.



Function sequence and possible faults





Function sequence and possible faults (cont.)

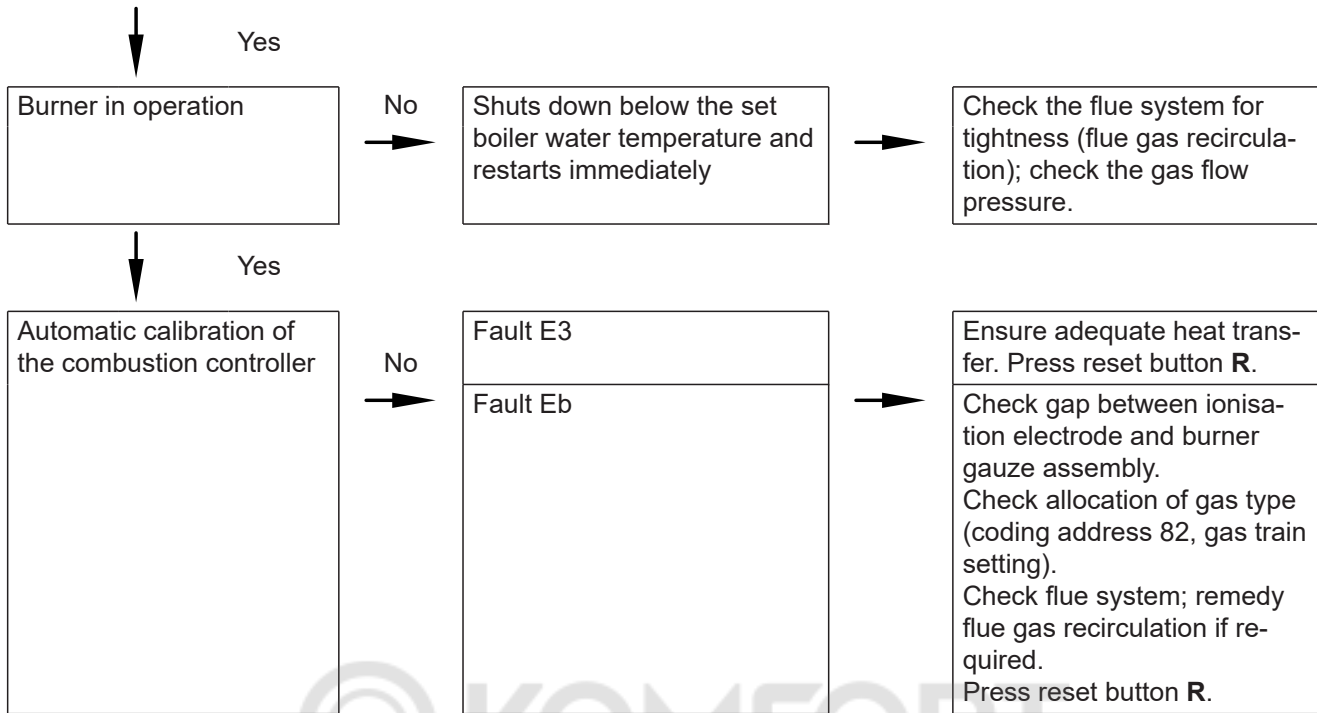

For further details regarding faults, see page 57.



Testing the static and supply pressure



Danger

CO formation as a result of incorrect burner adjustment can have serious health implications. Always carry out a CO test before and after work on gas appliances.

Operation with LPG

Purge the LPG tank twice on commissioning/replacement. Vent the tank and gas connection line thoroughly after purging.

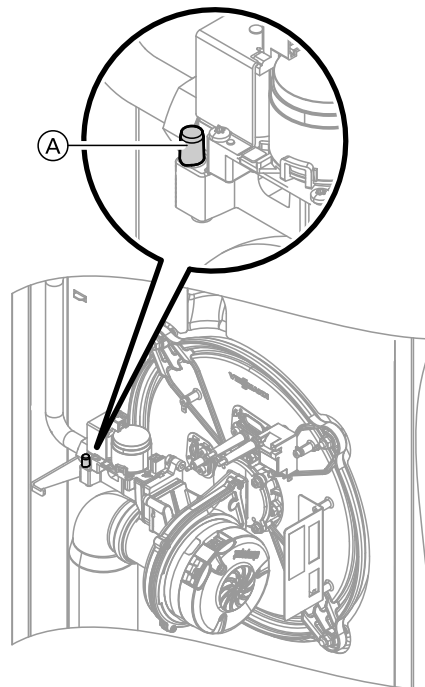

Fig. 5

1. Close the gas shut-off valve.
2. Release screw (A) in test connector "PE" on the gas solenoid valve, but do not remove it. Connect the pressure gauge.



Testing the static and supply pressure (cont.)

3. Open the gas shut-off valve.
4. Check the static pressure. Record the actual value in the report on page 96.
Set value: Max. 57.5 mbar (5.75 kPa)
5. Start the boiler.

Note

During commissioning, the appliance can enter a fault state if there are airlocks in the gas line. After approx. 5 s, press reset button R to reset the burner.

6. Measure the supply (flow) pressure.

Set value:

- Natural gas: 20 mbar (2 kPa)
- LPG: 50 mbar (5 kPa)

Note

Use a suitable measuring device with a resolution of at least 0.1 mbar (10 Pa) to check the supply pressure.

7. Record the actual value in the report on page 96. Implement measures as indicated in the table below.
8. Shut down the boiler, close the gas shut-off valve, remove the pressure gauge and close test connector (A) with the screw.
9. Open the gas shut-off valve and start the appliance.



Danger

Gas escaping from the test connector leads to a risk of explosion.
Check gas tightness at test connector (A).



Supply pressure (flow pressure)		Measures
With natural gas	For LPG	
Below 17.4 mbar (1.75 kPa)	Below 42.5 mbar (4.25 kPa)	Do not commission the boiler. Notify your gas supply utility or LPG supplier.
17.4 to 25 mbar (1.75 to 2.5 kPa)	42.5 to 57.5 mbar (4.25 to 5.75 kPa)	Start the boiler.
Above 25 mbar (2.5 kPa)	Above 57.5 mbar (5.75 kPa)	Connect a separate gas pressure governor upstream of the system. Set the pre-charge pressure to 20 mbar (2 kPa) for natural gas or 50 mbar (5 kPa) for LPG. Notify the gas supply utility or LPG supplier.



Setting the maximum heating output

A limit can be set on the maximum heating output for **heating mode**. The limit is set via the modulation range. The upper limit of the max. adjustable heating output is set by the boiler coding card.

1. Press **OK** and simultaneously for approx. 4 s.
2. **"Service functions"**
3. **"Max. output"**
4. **"Change?"** Select **"Yes"**.
A value is shown on the display (e.g. "85"). In the delivered condition, this value represents 100 % of rated heating output.
5. Set the required value.

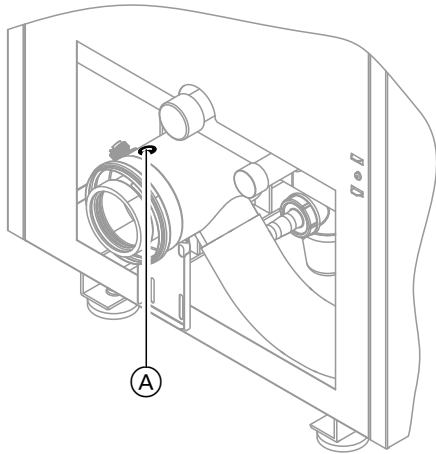

Fig. 6

Ⓐ Combustion air aperture

For balanced flue systems tested together with the heat generator, there is no requirement for a tightness test (overpressure test) during commissioning by the flue gas inspector.

In this case, we recommend that a simple tightness test is carried out during system commissioning. For this, check the CO₂ or O₂ concentration in the combustion air at the annular gap of the balanced flue pipe. If the CO₂ concentration is less than 0.2 % or the O₂ concentration is greater than 20.6 %, the flue pipe is deemed to be sufficiently gas-tight.

If actual CO₂ values are greater or O₂ values are lower, then pressure test the flue pipe with a static pressure of 200 Pa.



Please note

If the test port is not sealed, combustion air is drawn in from the room. After the tightness test, re-seal the test port with the plug.



Removing the burner and checking the burner gasket

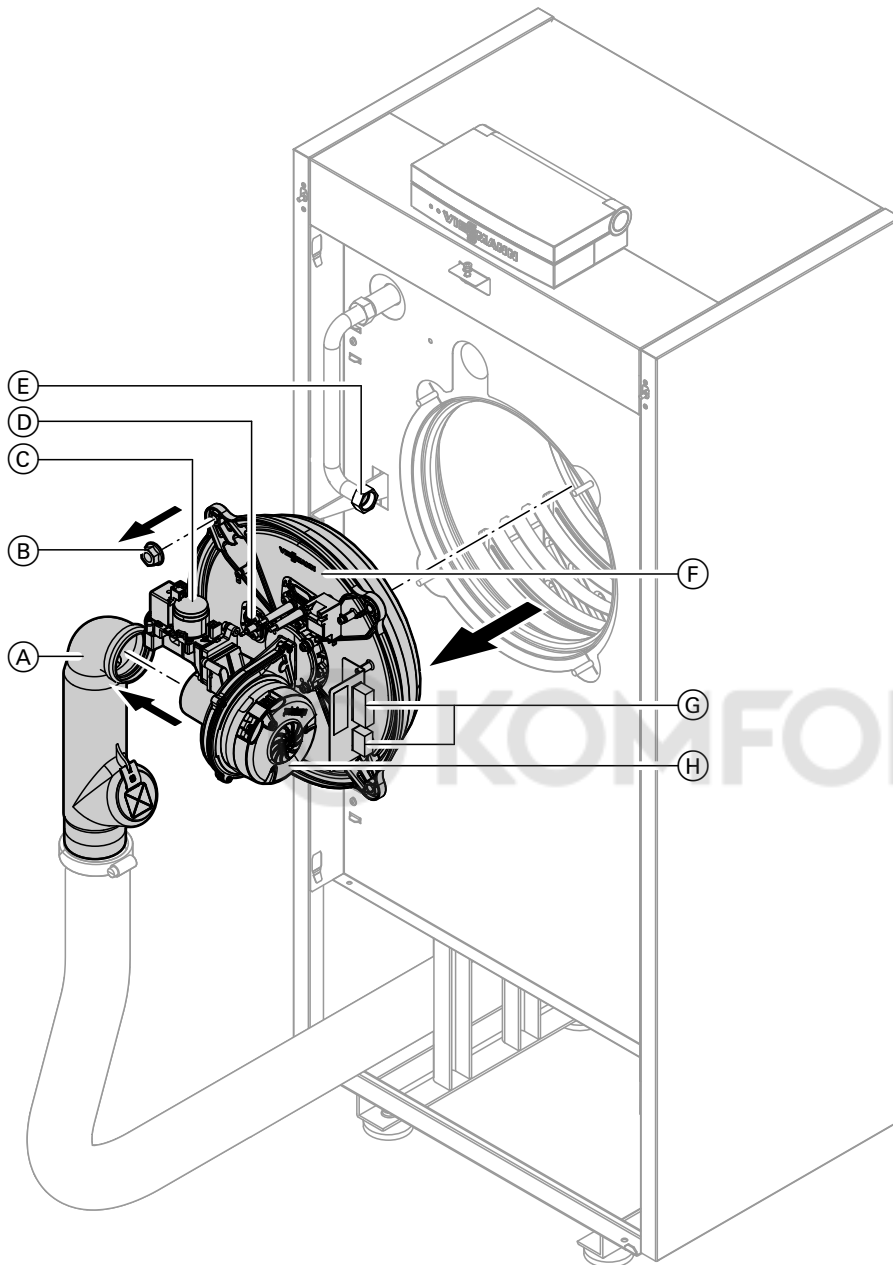

Fig. 7

1. Turn off the ON/OFF switch on the control unit and the power supply.
2. Close the gas shut-off valve and safeguard against reopening.
3. Detach electrical cables/leads to burner: Fan motor (H), gas solenoid valve (C), ionisation electrode (D), plug (G), ignition unit plug
4. Undo gas supply pipe fitting (E). Pull off ventilation air adaptor (A).





Removing the burner and checking the burner... (cont.)

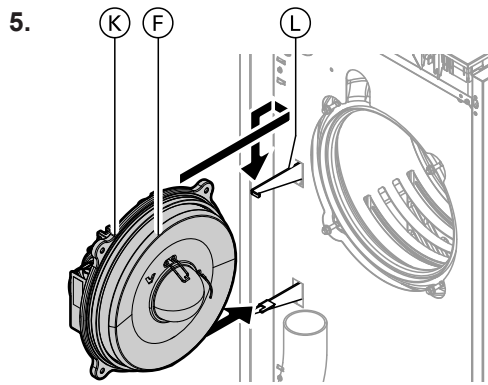

Fig. 8

Undo 4 nuts (B). Remove burner (F) and hook it into service retainer (L).



Please note

Prevent damage to the burner.
Always hook the burner into its service retainer.

6. Check burner gasket (K) for damage and replace if required.



Checking the burner gauze assembly and thermal insulation block

Replace the burner gauze assembly if the wire mesh is damaged.

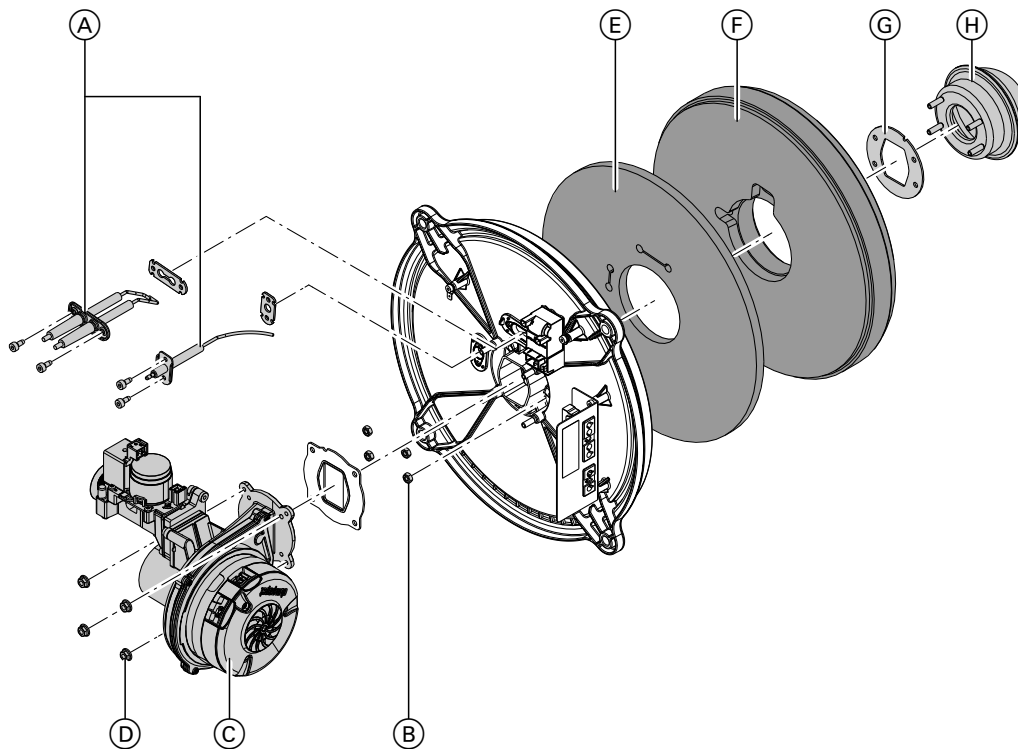

Fig. 9

1. Remove electrodes (A).

2. Undo 4 nuts (D). Remove fan together with gas solenoid valve (C).

3. Undo 3 nuts (B). Remove burner gauze assembly (H).

4. Remove thermal insulation block (F) together with thermal insulating mat (E).



Checking the burner gauze assembly and thermal... (cont.)

5. Remove burner gauze assembly gasket (G).
6. Check thermal insulation block (F) for damage and replace if required.
7. Insert thermal insulating mat (E) and thermal insulation block (F) according to the electrode position.
8. Insert new burner gauze assembly (H) together with new gasket (G). Secure with 4 nuts. Torque: 5 Nm
9. Install the fan together with the gas solenoid valve. Torque: 5 Nm

Note

Observe the positioning aid on the thermal insulation block.



Checking and adjusting the ignition and ionisation electrodes

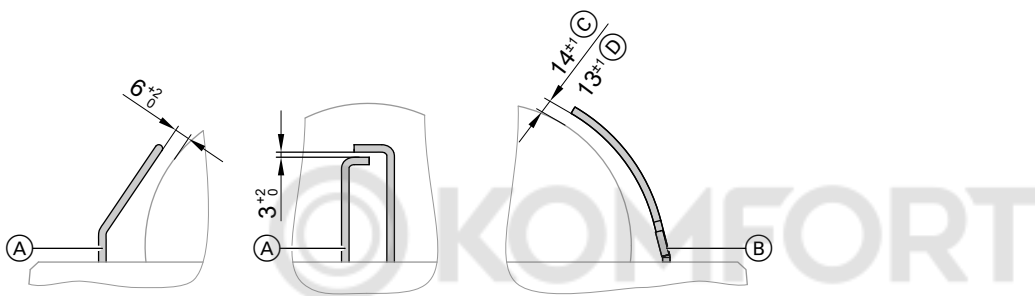

Fig. 10

- (A) Ignition electrodes
- (B) Ionisation electrode
- (C) Up to 35 kW
- (D) From 45 kW

1. Check the electrodes for wear and contamination.
2. Clean the electrodes with a small brush (not a wire brush) or sandpaper.
3. Check the electrode gaps. If the gaps are not as specified or the electrodes are damaged, replace and align the electrodes together with new gaskets. Tighten the electrode fixing screws with a torque of 3 Nm.

! **Please note**
 Damage to the burner gauze assembly will impair the burner function.
 Do not damage the wire gauze.



Separating the neutralising system (if installed) from the boiler and connecting the drain hose

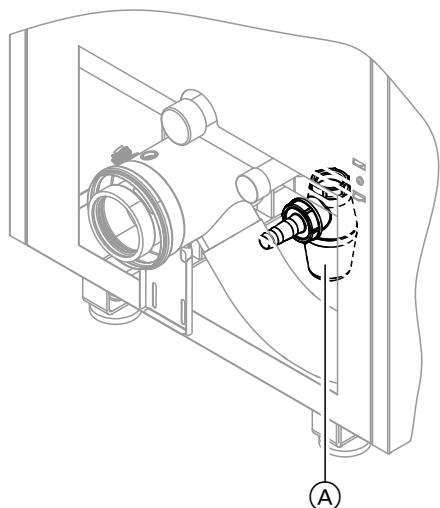

Fig. 11

1. Detach hose to neutralising system from trap (A).
2. Connect drain hose to trap (A) and route it to the drainage system



Cleaning the combustion chamber and heating surfaces

! **Please note**
Contact with unalloyed iron and scratches on parts in contact with flue gases can lead to corrosion.
Only use plastic brushes, not wire brushes or sharp objects.

1. Clean the combustion chamber and heating surfaces.
 - For normal cleaning, flush the heating surfaces thoroughly with a jet of water.
 - You may use cleaning agents if you notice stubborn residues, surface discolouration or soot deposits.
For this, observe the following:
 - Only use solvent-free cleaning agents. Ensure that no cleaning agent gets between the boiler shell and the thermal insulation.
 - Remove soot deposits with an alkaline cleaning agent with surfactant additive (e.g. Fauch condensing boiler cleaner or Sotin 300).
 - Remove coatings and surface discolouration (yellow-brown) with slightly acidic, chloride-free cleaning agents based on phosphoric acid (e.g. Antox 75 E).

2. Remove loosened deposits from the boiler. Thoroughly flush heating surfaces and the flue gas collector with a jet of water.



Danger

Loose residues and residual cleaning agents can lead to injury.
Wear goggles, protective gloves and protective clothing.



Cleaning agent manufacturer's details

Note

"Fauch" and "Antox 75 E"

Manufacturer: Hebro Chemie GmbH, Mönchengladbach

www.hebro-chemie.de

"Sotin 300"

Manufacturer: Sotin Chemische und technische Produkte GmbH & Co., Bad Kreuznach

www.sotin.de



Cleaning and reconnecting the condensate drain system

The condensate drain system comprises

- Flue gas collector
- Condensate drain
- Trap
- Neutralising system
- All hoses or pipes running between these parts

Note

Clean the inside of the condensate drain system at least annually.



Cleaning and reconnecting the condensate drain... (cont.)

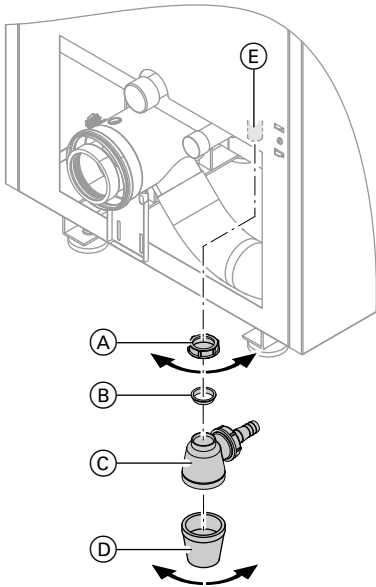

Fig. 12

1. Undo union nut (A) of trap (C). Remove union nut (A), gasket (B), then trap (C) together with bottom part (D) from boiler.

2. Clean the inside of inlet connector (E) with a brush.

3. Remove bottom part (D) of trap (C), then clean and refit it.

4. Fill trap (C) with water and refit to inlet connector (E).

Note

There is a risk of flue gas escaping if the trap is not filled with water.

5. Push union nut (A) together with gasket (B) onto condensate drain of flue gas collector. Push trap (C) onto condensate drain of flue gas collector. Insert gasket (B) and tighten with union nut (A) until finger-tight.

6. Undo drain hose to the drainage system from trap (C).

7. Clean the insides of the condensate drain system and the neutralising system (if installed).



Neutralising system operating instructions

8. Reconnect the neutralising system to trap (C).



Checking the condensate drain and neutralising system (if installed) for obstructions and leaks

Add water to the combustion chamber.

Note

The water must flow from the condensate drain without back pressure.

If necessary, clean the condensate drain again.



Checking the gaskets and thermal insulation parts on the boiler side

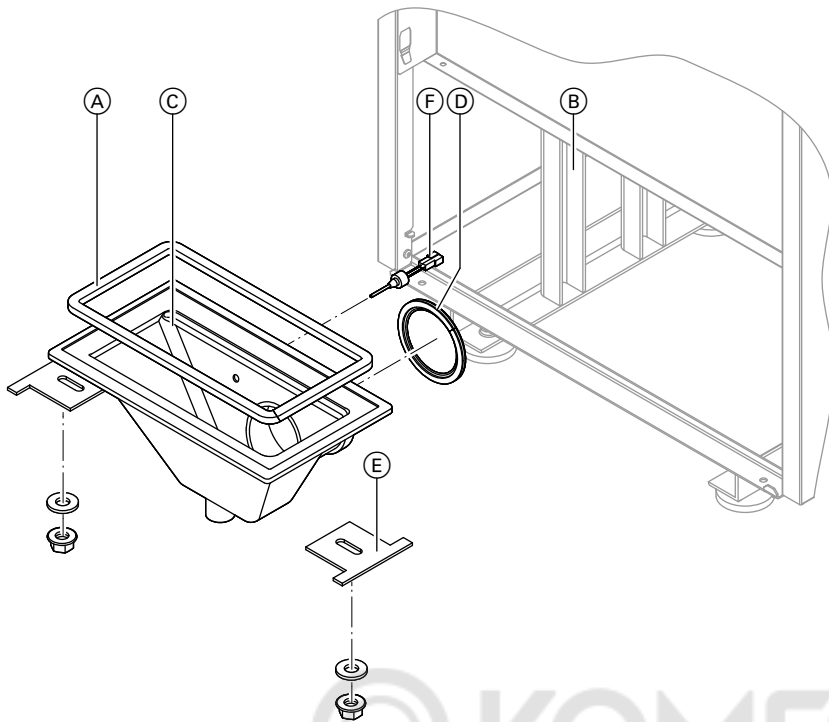

Fig. 13



Danger

Leaking systems can cause life threatening poisoning from carbon monoxide in the flue gas. Check the gaskets on flue gas collector (C) for leaks.

If required:

- Replace flue gas collector gasket (A).
- Replace lip seal (D).
- Retighten tensioning toggles (E).

1. Check flue gas collector seal (A) between flue gas collector (C) and boiler body (B) for leaks.
2. Check lip seal (D) on the boiler flue connection for leaks.

Note

Check the gaskets at full load operation using an inspection mirror or dew point indicator. If necessary, remove the thermal insulation sections. Traces of condensate on the outside of flue gas collector (C) also indicate a leak. If required, retighten tensioning toggle (E). Torque: 12 Nm

3. If required, remove flue gas collector and replace gaskets.
 - Prior to removing the flue gas collector, disconnect the plug at flue gas temperature sensor (F).
 - When installing, tighten tensioning toggle (E) to a torque of 12 Nm.

4. Check the fittings on the water side for leaks and replace the seals/gaskets if required.



Danger

There is a risk of injury when working on pressurised components. The connections on the heating water side must only be opened after the boiler has been depressurised. Only drain the boiler with a suction pump when the boiler air vent valve is open.

5. Check the boiler thermal insulation for seating. Adjust if required or replace if damaged.



Checking the expansion vessel and system pressure

Note

Check when system is cold.

1. Drain the system or close the cap valve on the expansion vessel. Reduce pressure until the pressure gauge shows "0".
2. If the pre-charge pressure of the expansion vessel is lower than the static system pressure, top up with nitrogen until the pre-charge pressure is 0.1 to 0.2 bar (10 to 20 kPa) higher.



Checking the expansion vessel and system... (cont.)

- Top up with water until the charge pressure of the cooled system is 0.1 to 0.2 bar (10 to 20 kPa) higher than the pre-charge pressure of the expansion vessel.
 Permiss. operating pressure: 3 bar (0.3 MPa)
 Minimum operating pressure: 0.5 bar (50 kPa)

Note

The minimum operating pressure is essential for safe operation. It can be ensured with a minimum pressure switch (one per system for multi boiler systems).



Checking the water quality

Enter the amount of top-up water and the total hardness of the feed and boiler water into the table in the appendix on page 95.
 For water quality requirements, see page 93.

The total hardness of the feed and top-up water must not exceed the standard values specified by VDI 2035 (see page 93).
 The pH value should be between 8.2 and 10.0.



Checking the mixer for ease of operation and leaks

- Remove the motorised lever from the mixer handle.
- Check the mixer for ease of operation.
- Check the mixer for leaks. In the event of a leak, replace the O-rings.
- Click the motorised lever into place.



Checking all connections on the heating water and DHW sides for leaks



Checking the safety valve function



Installing the burner

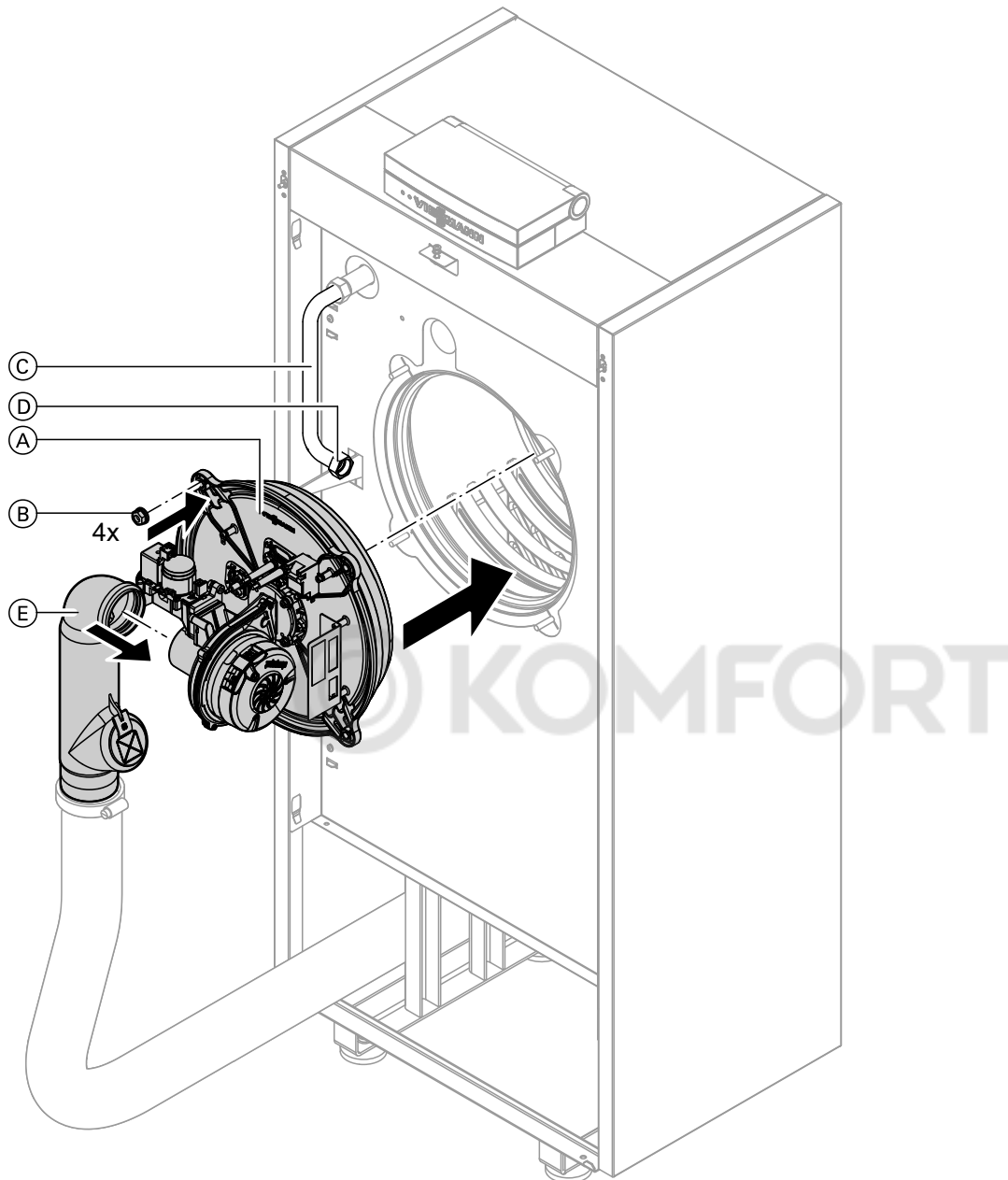



Fig. 14

1. Insert burner (A). Secure in place by tightening the 4 nuts (B) diagonally.
Torque: 4 Nm
2. Fit gas connection pipe (C) together with new gasket (D).
Torque: 15 Nm
3. Plug in ventilation air adaptor (E).
4. Connect the electrical cables to the corresponding components.
5.  **Danger**
Leaks can result in poisoning by flue gas. Check the burner door for leaks using an inspection mirror. If necessary check the gasket for correct seating and realign.



Checking the firm seating of electrical connections



Checking all gas equipment for leaks at operating pressure



Danger

Escaping gas leads to a risk of explosion.
Check gas equipment for leaks.

Note

Only use suitable and approved leak detection agents (EN 14291) and devices for the leak test. Leak detection agents with unsuitable constituents (e.g. nitrides, sulphides) can cause material damage. Remove residues of the leak detection agent after testing.



Checking the combustion quality

The electronic combustion controller automatically ensures optimum combustion quality. During commissioning/maintenance, only the combustion values need to be checked. For this, check the CO₂ or O₂ content. For a description of the electronic combustion controller functions, see page 88.

Note

To prevent operating faults and damage, operate the appliance with uncontaminated combustion air.

CO₂ or O₂ content

- The CO₂ content must be within the following limits for the lower and upper heating output respectively:
 - 7.7 to 9.2 % for natural gas E and LL
 - 9.3 to 10.9 % for LPG P
- The O₂ content must be between 4.4 and 6.9 % for all gas types.

If the actual CO₂ or O₂ values lie outside their respective ranges, proceed as follows:

- Check the balanced flue system for leaks; see page 18.
- Check the ionisation electrode and connecting cable, see page 21.

Note

During commissioning, the combustion controller carries out an automatic calibration. Allow approx. 30 s after the burner has started before testing the emissions.

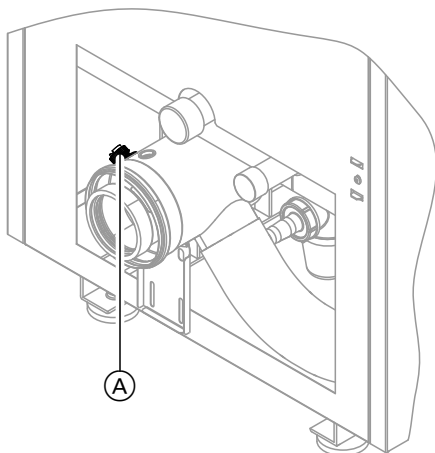

Fig. 15

1. Connect a flue gas analyser at flue gas port (A) on the boiler flue connection.
2. Open the gas shut-off valve, start the boiler and create a heat demand.
3. Set the lower heating output (see page 27).
4. Check the CO₂ content. If the value deviates from the aforementioned ranges by more than 1 %, implement the measures detailed on page 27.
5. Enter the value into the report.
6. Set the upper heating output (see page 27).
7. Check the CO₂ content. If the value deviates from the aforementioned ranges by more than 1 %, implement the measures detailed on page 27.
8. After testing, press **OK**.
9. Enter the value into the report.

Selecting the upper/lower heating output

1. Press **OK** and **≡** simultaneously for approx. 4 s.
2. "Actuator test"
3. Select the lower heating output:
Select "**Base load OFF**". Display shows: "**Base load ON**" and the burner runs at its lower heating output.
4. Select the upper heating output:
Select "**Full load OFF**". Display shows: "**Full load ON**" and the burner runs at its upper heating output.
5. End output selection with **↶**.



Checking the ventilation air apertures in the installation room (open flue operation)



Checking the external LPG safety valve (if installed)



Matching the control unit to the heating system

The control unit must be matched to the system equipment level. Various system components are recognised automatically by the control unit and the relevant codes are set automatically.

■ For coding steps, see page 32.



Adjusting the heating curves

The heating curves illustrate the relationship between the outside temperature and the boiler water or flow temperature.

To put it simply, the lower the outside temperature, the higher the boiler water or flow temperature.

The boiler water or flow temperature in turn affects the room temperature.

Note

If the heating system includes heating circuits with mixers, then the flow temperature of the heating circuit without mixer is higher by a selected differential (8 K in the delivered condition) than the flow temperature of the heating circuits with mixers.

The differential temperature is adjustable via coding address "9F" in the "General" group.

Settings in the delivered condition:

- Slope = 1.4
- Level = 0

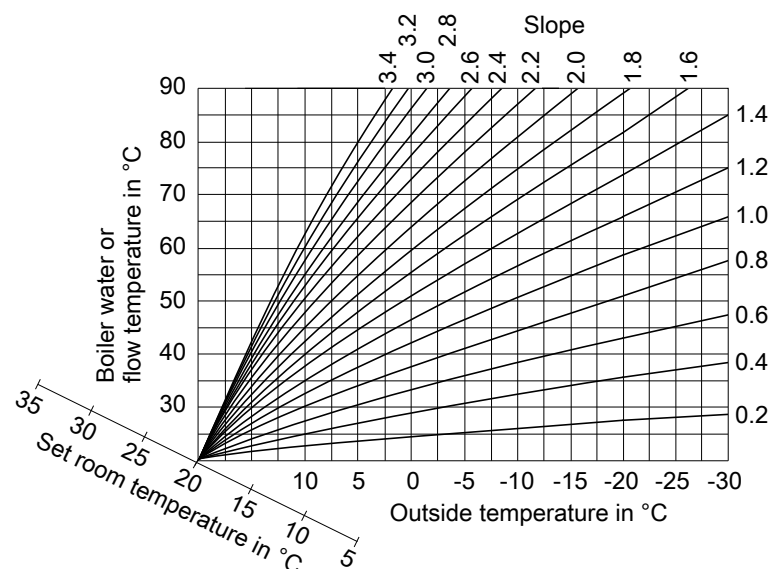

Fig. 16

Slope setting ranges:

- Underfloor heating systems: 0.2 to 0.8
- Low temperature heating systems: 0.8 to 1.6

Selecting the set room temperature

Individually adjustable for each heating circuit.

The heating curve is offset along the set room temperature axis. With the heating circuit pump logic function active, the curve modifies the start and stop characteristics of the heating circuit pump.



Adjusting the heating curves (cont.)

Standard set room temperature

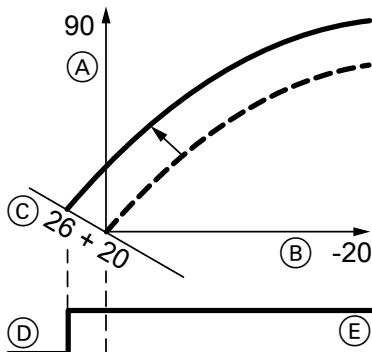

Fig. 17 Example 1: Adjustment of the standard set room temperature from 20 to 26 °C

- (A) Boiler water temperature or flow temperature in °C
- (B) Outside temperature in °C
- (C) Set room temperature in °C
- (D) Heating circuit pump "OFF"
- (E) Heating circuit pump "ON"

Changing the standard set room temperature



Operating instructions

Reduced set room temperature

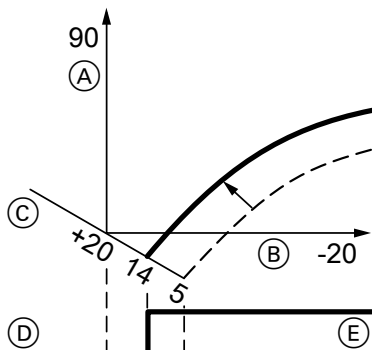

Fig. 18 Example 2: Adjustment of the reduced set room temperature from 5 °C to 14 °C

- (A) Boiler water temperature or flow temperature in °C
- (B) Outside temperature in °C
- (C) Set room temperature in °C
- (D) Heating circuit pump "OFF"
- (E) Heating circuit pump "ON"

Changing the reduced set room temperature



Operating instructions

Changing the slope and level

Individually adjustable for each heating circuit.

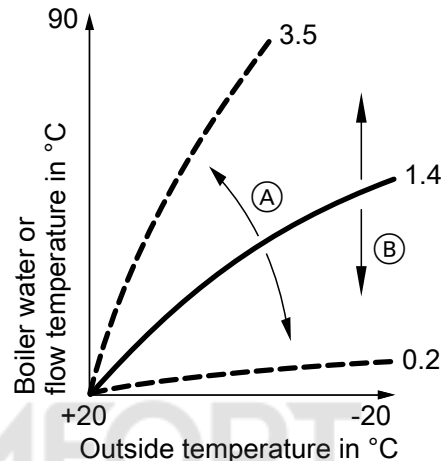

Fig. 19

- (A) Changing the slope
- (B) Changing the level (vertical parallel offset of the heating curve)

Press the following buttons for the extended menu:

1. to call up the menu.
2. "Heating" select
3. to select the heating circuit.
4. "Heating curve" select
5. "Slope" or "Level" to change the heating curve in accordance with requirements.



Connecting the control unit to the LON

The LON communication module must be plugged in.

Note

The data transfer via LON can take several minutes.

Example: Single boiler system with Vitotronic 200-H and Vitocom 200

Set LON subscriber numbers and further functions via code 2 (see the following table).



Connecting the control unit to the LON (cont.)

Note

The same subscriber number must **not** be allocated twice within the LON.

Only one Vitotronic may be programmed as fault manager.

All coding addresses in the table are listed in the "General" group.

Boiler control unit	Vitotronic 200-H	Vitotronic 200-H	Vitocom
Subscriber no. 1 Code "77:1"	Subscriber no. 10 Code "77:10"	Subscriber no. 11 Set code "77:11".	Subscriber no. 99
Control unit is fault manager. Code "79:1"	Control unit is not fault manager. Code "79:0"	Control unit is not fault manager. Code "79:0"	Device is fault manager.
Control unit transmits the time. Code "7b:1"	Control unit receives the time. Set code "81:3".	Control unit receives the time. Set code "81:3".	Device receives the time.
Control unit sends outside temperature. Set code "97:2".	Control unit receives outside temperature. Set code "97:1".	Control unit receives outside temperature. Set code "97:1".	—
Viessmann system number. Code "98:1"	Viessmann system number. Code "98:1"	Viessmann system number. Code "98:1"	—
LON subscriber fault monitoring. Code "9C:20"	LON subscriber fault monitoring. Code "9C:20"	LON subscriber fault monitoring. Code "9C:20"	—

Carrying out a LON subscriber check

The subscriber check is used to test communication with the system devices connected to the fault manager.

Requirements:

- The control unit must be programmed as **fault manager** (code "79:1" in the "General" group).
- The LON subscriber number must be programmed in all control units.
- The LON subscriber list in the fault manager must be up to date.

Service menu:

1. Press **OK** and simultaneously for approx. 4 s.
2. "Service functions"

3. "Subscriber check"

4. Select subscriber (e.g. subscriber 10).
5. Start the subscriber check with **"OK"**.

- Successfully tested subscribers are designated with **"OK"**.
- Unsuccessfully tested subscribers are identified with **"Not OK"**.

Note

To perform another subscriber check:
Create a new subscriber list with **"Delete list?"** (subscriber list is updated).

Note

During the subscriber check, the display of the relevant subscriber shows the subscriber no. and **"Wink"** for approx. 1 min.



Checking and resetting the "Service" display

After the limits specified in coding addresses "21" and "23" in the "Boiler" group have been reached, the red fault indicator flashes and **"Service"** and appear on the programming unit display.

Acknowledging and resetting service

Press **OK** to acknowledge a service message.



Checking and resetting the "Service" display (cont.)

Note

An acknowledged service message that was not reset reappears the following Monday.

After a service has been carried out (resetting service)

1. Press **OK** and simultaneously for approx. 4 s.

2. "Service functions"

3. "Service reset"

Note

The selected service parameters for hours run and interval restart at 0.



Mounting the front panel

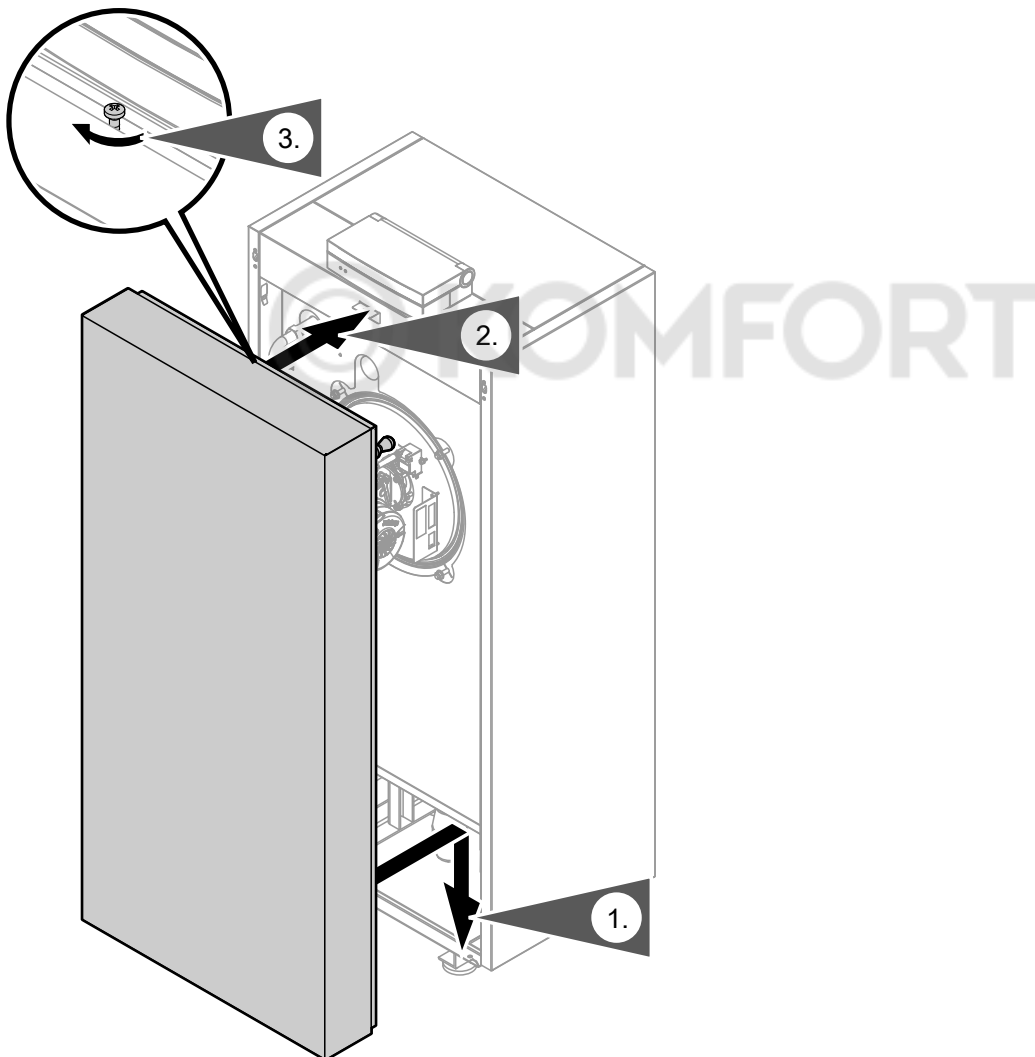

Fig. 20



Instructing the system user

The system installer should hand the operating instructions to the system user and explain to the user how to operate the system.

Calling up coding level 1

- On weather-compensated control units, codes are displayed as plain text.
- Codes that are not assigned, due to the heating system equipment level or the setting of other codes, are not displayed.
- Heating systems with one heating circuit without mixer and one or two heating circuits with mixer: Below, the heating circuit without mixer is designated **"Heating circuit 1"** and the heating circuits with mixer as **"Heating circuit 2"** or **"Heating circuit 3"**. If the heating circuits were given individual designations, the selected designation and **"HC1"**, **"HC2"** or **"HC3"** appear instead.

The codes are divided into groups

- "General"**
- "Boiler"**
- "DHW"**
- "Solar"**
- "Heating circuit 1/2/3"**
- "All codes std device"**
In this group, all coding addresses from coding level 1 (except the coding addresses of the **"Solar"** group) are displayed in ascending order.
- "Standard setting"**

Calling up code 1

Service menu:

- Press **OK** and  simultaneously for approx. 4 s.
- "Coding level 1"**
- Select the group of required coding addresses.
- Select the coding address.
- Set the value according to the following tables and confirm with **OK**.

Resetting all codes to the factory setting

Select **"Standard setting"**.

Note

This also resets the codes at coding level 2.

General

Coding

Coding in the delivered condition		Possible change	
System design			
00:1	System version 1: One heating circuit without mixer A1 (heating circuit 1), without DHW heating	00:2 to 00:10	For system schemes, see the following table:
Value, address 00: ...	Description		
2	1 heating circuit without mixer A1 (heating circuit 1), with DHW heating (code is set automatically)		
3	1 heating circuit with mixer M2 (heating circuit 2), without DHW heating		
4	1 heating circuit with mixer M2 (heating circuit 2), with DHW heating		
5	1 heating circuit without mixer A1 (heating circuit 1) and 1 heating circuit with mixer M2 (heating circuit 2), without DHW heating (code is set automatically)		
6	1 heating circuit without mixer A1 (heating circuit 1) and 1 heating circuit with mixer M2 (heating circuit 2), with DHW heating (code is set automatically)		
7	1 heating circuit with mixer M2 (heating circuit 2) and 1 heating circuit with mixer M3 (heating circuit 3), without DHW heating		
8	1 heating circuit with mixer M2 (heating circuit 2) and 1 heating circuit with mixer M3 (heating circuit 3), with DHW heating		

General (cont.)

Value, address 00: ...	Description
9	1 heating circuit without mixer A1 (heating circuit 1), 1 heating circuit with mixer M2 (heating circuit 2) and 1 heating circuit with mixer M3 (heating circuit 3), without DHW heating (code is set automatically)
10	1 heating circuit without mixer A1 (heating circuit 1), 1 heating circuit with mixer M2 (heating circuit 2) and 1 heating circuit with mixer M3 (heating circuit 3), with DHW heating (code is set automatically)



System examples

Coding in the delivered condition		Possible change	
Code 1			
77:1	LON subscriber number, if LON communication module is installed	77:2 to 77:99	LON subscriber number, adjustable from 1 to 99: 1 = Boiler 2 - 5 = Do not adjust 10 - 98 = Vitotronic 200-H 99 = Vitocom Note <i>Allocate each number only once.</i>
Detached house/apartment building			
7F:1	Detached house	7F:0	Apartment building Holiday program and time program for DHW heating can be set separately
Lock out controls			
8F:0	Operation enabled in standard menu and extended menu. Note <i>The relevant code is only enabled when you exit the service menu.</i>	8F:1	Operation is blocked in standard menu and extended menu. Emissions test mode can be activated.
		8F:2	Operation is enabled in standard menu, but blocked in extended menu. Emissions test mode can be activated.
Set flow temperature for external demand			
9b:70	Set flow temperature for external demand 70 °C	9b:0 to 9b:127	Set flow temperature for external demand adjustable from 0 to 127 °C (limited by boiler-specific parameters)

Boiler**Coding**

Coding in the delivered condition		Possible change	
Single/multi boiler system			
01:1	Do not adjust.		

Boiler (cont.)

Coding in the delivered condition		Possible change	
Burner service in 100 hours			
21:0	No service interval set (in hours run)	21:1 to 21:100	The number of hours run before the burner should be serviced is adjustable from 100 to 10,000 h One adjusting step $\hat{=}$ 100 h
Service interval in months			
23:0	No time set for burner service interval	23:1 to 23:24	Interval adjustable from 1 to 24 months
Service status			
24:0	"Service" not shown on the display	24:1	"Service" is shown on the display (address is automatically set and must be manually reset after a service has been carried out)
Filling/Venting			
2F:0	Do not adjust.		

DHW**Coding**

Coding in the delivered condition		Possible change	
Set DHW temperature reheating suppression			
67:40	For solar DHW heating: Set DHW temperature 40 °C. Reheating is suppressed above the selected set temperature. (Boiler only starts as backup if the rise in the cylinder temperature is too low.)	67:0 to 67:95	Set DHW temperature adjustable from 0 to 95 °C (limited by boiler-specific parameters)
Enable DHW circulation pump			
73:0	DHW circulation pump: "ON" according to time program	73:1 to 73:6	"ON" from once per hour for 5 min up to 6 times per hour for 5 min during the time program
		73:7	Constantly "ON"

Solar**Note**

The solar group is only displayed if a solar control module, type SM1, is connected.

Solar (cont.)**Coding**

Coding in the delivered condition		Possible change	
Speed control solar circuit pump			
02:...	Coding dependent on the software version of solar control module SM1/SM1A	02:0	Solar circuit pump is not speed-controlled
		02:1	With wave packet control function Never adjust
		02:2	Solar circuit pump is speed-controlled with PWM control
Maximum cylinder temperature			
08:60	The solar circuit pump is switched off when the actual DHW temperature reaches the maximum cylinder temperature (60 °C).	08:10 to 08:90	Set DHW temperature adjustable from 10 to 90 °C.
Stagnation time reduction			
0A:5	Temperature differential for stagnation time reduction (reduction in the speed of the solar circuit pump to protect system components and heat transfer medium) 5 K.	0A:0	Stagnation time reduction not active.
		0A:1 to 0A:40	Temperature differential adjustable from 1 to 40 K.
Flow rate solar circuit			
0F:70	Solar circuit flow rate at the maximum pump speed 7 l/min.	0F:1 to 0F:255	Flow rate adjustable from 0.1 to 25.5 l/min, 1 step \triangleq 0.1 l/min.
Extended solar control functions			
20:0	No extended control function enabled	20:1	Auxiliary function for DHW heating
		20:2	Differential temperature control 2.
		20:3	Differential temperature control 2 and auxiliary function.
		20:4	Differential temperature control 2 for central heating backup.
		20:5	Thermostat function
		20:6	Thermostat function and auxiliary function
		20:7	Solar heating via external heat exchanger without additional temperature sensor
		20:8	Solar heating via external heat exchanger with additional temperature sensor
20:9	Solar heating of 2 DHW cylinders		

Heating circuit 1, heating circuit 2, heating circuit 3

Coding

Coding in the delivered condition		Possible change	
Priority DHW heating			
A2:2	Cylinder priority for heating circuit pump	A2:0	No cylinder priority for heating circuit pump
		A2:1	Cylinder priority for mixers: The mixer is closed during cylinder heating. The heating circuit pump is running.
		A2:3 to A2:15	Modulating priority for mixers: The heating circuit receives a reduced amount of heat.

Economy function outside temperature

A5:5	With heating circuit pump logic function (economy mode): Heating circuit pump "OFF" when outside temperature (OT) is 1 K higher than set room temperature (RT_{set}) $OT > RT_{set} + 1 K$	A5:0	Without heating circuit pump logic function
		A5:1 to A5:15	With heating circuit pump logic function: Heating circuit pump "OFF" (see the following table)

Parameter address A5:...	With heating circuit pump logic function: Heating circuit pump "OFF"
1	$OT > RT_{set} + 5 K$
2	$OT > RT_{set} + 4 K$
3	$OT > RT_{set} + 3 K$
4	$OT > RT_{set} + 2 K$
5	$OT > RT_{set} + 1 K$
6	$OT > RT_{set}$
7 to 15	$OT > RT_{set} - 1 K$ $OT > RT_{set} - 9 K$

Coding in the delivered condition		Possible change	
Extended economy function adjusted outside temperature			
A6:36	Extended economy mode not active	A6:5 to A6:35	Extended economy mode active: The burner and heating circuit pump are switched off at a variable value, adjustable from 5 to 35 °C plus 1 °C. Mixer is being closed. The basis for this is the adjusted outside temperature. The outside temperature is derived from the actual outside temperature and a time constant that takes account of the way an average building cools down.

Heating circuit 1, heating circuit 2, heating... (cont.)

Coding in the delivered condition		Possible change	
Extended economy function mixer			
A7:0	Without mixer economy function (only for heating circuits with mixer)	A7:1	With mixer economy function (extended heating circuit pump logic): Heating circuit pump also "OFF": <ul style="list-style-type: none"> ▪ If the mixer has been trying to close for more than 20 min. Heating circuit pump "ON": <ul style="list-style-type: none"> ▪ If the mixer changes to control function. ▪ If there is a risk of frost
Pump idle time, transition reduced mode			
A9:7	With pump idle time: Heating circuit pump "OFF" if set value is modified by changing the operating mode or changing the set room temperature	A9:0	Without pump idle time
		A9:1 to A9:15	With pump idle time, adjustable from 1 to 15
Weather-compensated/room temperature hook-up			
b0:0	With remote control: Heating mode/reduced. Operation: Weather-compensated (change code only for the heating circuit with mixer)	b0:1	Heating mode: Weather-compensated Reduced mode: With room temperature hook-up
		b0:2	Heating mode: With room temperature hook-up Reduced mode: Weather-compensated
		b0:3	Heating mode/reduced mode: With room temperature hook-up
Economy function, room temperature			
b5:0	With remote control: No room temperature-dependent heating circuit pump logic function (change code only for heating circuit with mixer)	b5:1 to b5:8	For heating circuit pump logic function, see the following table:

Parameter address b5:...	With heating circuit pump logic function:	
	Heating circuit pump "OFF"	Heating circuit pump "ON"
1	$RT_{\text{actual}} > RT_{\text{set}} + 5 \text{ K}$	$RT_{\text{actual}} < RT_{\text{set}} + 4 \text{ K}$
2	$RT_{\text{actual}} > RT_{\text{set}} + 4 \text{ K}$	$RT_{\text{actual}} < RT_{\text{set}} + 3 \text{ K}$
3	$RT_{\text{actual}} > RT_{\text{set}} + 3 \text{ K}$	$RT_{\text{actual}} < RT_{\text{set}} + 2 \text{ K}$
4	$RT_{\text{actual}} > RT_{\text{set}} + 2 \text{ K}$	$RT_{\text{actual}} < RT_{\text{set}} + 1 \text{ K}$
5	$RT_{\text{actual}} > RT_{\text{set}} + 1 \text{ K}$	$RT_{\text{actual}} < RT_{\text{set}}$
6	$RT_{\text{actual}} > RT_{\text{set}}$	$RT_{\text{actual}} < RT_{\text{set}} - 1 \text{ K}$
7	$RT_{\text{actual}} > RT_{\text{set}} - 1 \text{ K}$	$RT_{\text{actual}} < RT_{\text{set}} - 2 \text{ K}$
8	$RT_{\text{actual}} > RT_{\text{set}} - 2 \text{ K}$	$RT_{\text{actual}} < RT_{\text{set}} - 3 \text{ K}$

Coding in the delivered condition		Possible change	
Min. flow temperature heating circuit			
C5:20	Electronic minimum flow temperature limit 20 °C	C5:1 to C5:127	Minimum limit adjustable from 1 to 127 °C (limited by boiler-specific parameters)

Heating circuit 1, heating circuit 2, heating... (cont.)

Coding in the delivered condition		Possible change	
Max. flow temperature heating circuit			
C6:74	Electronic maximum flow temperature limit set to 74 °C	C6:10 to C6:127	Maximum limit adjustable from 10 to 127 °C (limited by boiler-specific parameters)
Heating program - changeover			
d5:0	External operating program changeover switches the operating program to "Constant operation at reduced room temperature" or "Standby mode"	d5:1	The external operating program changeover switches to "Continuous operation at standard room temperature" (subject to coding address 3A, 3b and 3C)
Ext. operating program changeover to heating circuit			
d8:0	No operating program changeover via EA1 extension	d8:1	Operating program changeover via input DE1 at EA1 extension
		d8:2	Operating program changeover via input DE2 at EA1 extension
		d8:3	Operating program changeover via input DE3 at EA1 extension
Screed drying			
F1:0	Screed drying not active	F1:1 to F1:6	Screed drying adjustable in accordance with 6 selectable temperature/time profiles (see page 85)
		F1:15	Constant flow temperature 20 °C
Party mode time limit			
F2:8	Time limit for party mode or external operating program changeover via pushbutton: 8 h*	F2:0	No time limit for party mode
		F2:1 to F2:12	Time limit adjustable from 1 to 12 h
Start temperature raising			
F8:-5	Temperature limit for terminating reduced mode -5 °C; see example on page 87. Observe setting of coding address "A3".	F8:+10 to F8:-60	Temperature limit adjustable from +10 to -60 °C
		F8:-61	Function inactive
End temperature raising			
F9:-14	Temperature limit for raising the reduced set room temperature -14 °C; see example on page 87.	F9:+10 to F9:-60	Limit for raising the set room temperature to the value selected for standard mode adjustable from +10 to -60 °C
Set flow temperature increase			
FA:20	Set boiler water temperature or set flow temperature is raised by 20 % when switching from operation with reduced room temperature to operation with standard room temperature. See example on page 87.	FA:0 to FA:50	Temperature increase adjustable from 0 to 50 %
Duration set flow temperature increase			
Fb:30	Duration for raising the set boiler water or flow temperature (see coding address "FA") 60 min. See example on page 87.	Fb:0 to Fb:150	Duration adjustable from 0 to 300 min; 1 step \approx 2 min

* In the "Heating and DHW" program, party mode ends **automatically** when the system changes over to operation at standard room temperature.

Calling up coding level 2

- In coding level 2 **all** codes are accessible.
- Codes that are not assigned, due to the heating system equipment level or the setting of other codes, are not displayed.
- Below, the heating circuit without mixer is designated "**Heating circuit 1**" and the heating circuits with mixer as "**Heating circuit 2**" or "**Heating circuit 3**". If the heating circuits were given individual designations, the selected designation and "**HC1**", "**HC2**" or "**HC3**" appear instead.

The codes are divided into groups



- "General"
- "Boiler"
- "DHW"
- "Solar"
- "Heating circuit 1/2/3"
- "All codes std device"

In this group, all coding addresses (except the coding addresses from the "Solar" group) are displayed in ascending order.

- "Standard setting"

Calling up code 2

Service menu:

1. Press **OK** and  simultaneously for approx. 4 s.
2. Press **OK** and  simultaneously for approx. 4 s.
3. "**Coding level 2**"
4. Select the group of required coding addresses.
5. Select the coding address.
6. Set the value according to the following tables and confirm with **OK**.

Resetting all codes to the factory setting

Select "**Standard setting**".

Note

This also resets the codes at coding level 1.

General

Coding

Coding in the delivered condition		Possible change	
00:1	System version 1: One heating circuit without mixer A1 (heating circuit 1), without DHW heating	00:2 to 00:10	For system schemes, see the following table:

Value, address 00: ...	Description
2	1 heating circuit without mixer A1 (heating circuit 1), with DHW heating (code is set automatically)
3	1 heating circuit with mixer M2 (heating circuit 2), without DHW heating
4	1 heating circuit with mixer M2 (heating circuit 2), with DHW heating
5	1 heating circuit without mixer A1 (heating circuit 1) and 1 heating circuit with mixer M2 (heating circuit 2), without DHW heating (code is set automatically)
6	1 heating circuit without mixer A1 (heating circuit 1) and 1 heating circuit with mixer M2 (heating circuit 2), with DHW heating (code is set automatically)
7	1 heating circuit with mixer M2 (heating circuit 2) and 1 heating circuit with mixer M3 (heating circuit 3), without DHW heating
8	1 heating circuit with mixer M2 (heating circuit 2) and 1 heating circuit with mixer M3 (heating circuit 3), with DHW heating
9	1 heating circuit without mixer A1 (heating circuit 1), 1 heating circuit with mixer M2 (heating circuit 2) and 1 heating circuit with mixer M3 (heating circuit 3), without DHW heating (code is set automatically)
10	1 heating circuit without mixer A1 (heating circuit 1), 1 heating circuit with mixer M2 (heating circuit 2) and 1 heating circuit with mixer M3 (heating circuit 3), with DHW heating (code is set automatically)



System examples

Coding in the delivered condition		Possible change	
11:≠9	No access to the coding addresses for the parameters of the combustion controller	11:9	Access to the coding addresses for the parameters of the combustion controller open
2A:0	Do not adjust.		
2d:0	Do not adjust.		
32:0	Do not adjust.		
35:0	Without EA1 extension	35:1	With EA1 extension (automatic recognition)
36:0	Function of output [157] at EA1 extension: Fault message	36:1	Function of output [157]: Feed pump
		36:2	Function of output [157]: DHW circulation pump
3A:0	Function of input DE1 at EA1 extension: Not assigned	3A:1	Function of input DE1: Operating program changeover
		3A:2	Function of input DE1: External demand with set flow temperature Setting of set flow temperature for external demand: Code 9b Function, circulation pump for cylinder heating: Coding address 5F Function, heating circuit pumps: Coding address D7
		3A:3	Function of input DE1: External blocking Function, circulation pump for cylinder heating: Coding address 5E Function, heating circuit pumps: Coding address D6
		3A:4	Function of input DE1: External blocking with fault message input Function, circulation pump for cylinder heating: Coding address 5E Function, heating circuit pumps: Coding address D6
		3A:5	Function of input DE1: Fault message input
		3A:6	Function of input DE1: Brief operation of DHW circulation pump (push-button function). Setting of DHW circulation pump runtime: Coding address 3d
3b:0	Function of input DE2 at EA1 extension: Not assigned	3b:1	Function of input DE2: Operating program changeover
		3b:2	Function of input DE2: External demand with set flow temperature Setting of set flow temperature for external demand: Code 9b Function, circulation pump for cylinder heating: Coding address 5F Function, heating circuit pumps: Coding address D7

General (cont.)

Coding in the delivered condition		Possible change	
		3b:3	Function of input DE2: External blocking Function, circulation pump for cylinder heating: Coding address 5F Function, heating circuit pumps: Coding address D7
		3b:4	Function of input DE2: External blocking with fault message input Function, circulation pump for cylinder heating: Coding address 5E Function, heating circuit pumps: Coding address D6
		3b:5	Function of input DE2: Fault message input
		3b:6	Function of input DE2: Brief operation of DHW circulation pump (push-button function). Setting of DHW circulation pump runtime: Coding address 3d
3C:0	Function of input DE3 at EA1 extension: Not assigned	3C:1	Function of input DE3: Operating program changeover
		3C:2	Function of input DE3: External demand with set flow temperature Setting of set flow temperature for external demand: Code 9b Function, circulation pump for cylinder heating: Coding address 5F Function, heating circuit pumps: Coding address D7
		3C:3	Function of input DE3: External blocking Function, circulation pump for cylinder heating: Coding address 5F Function, heating circuit pumps: Coding address D7
		3C:4	Function of input DE3: External blocking with fault message input Function, circulation pump for cylinder heating: Coding address 5E Function, heating circuit pumps: Coding address D6
		3C:5	Function of input DE3: Fault message input
		3C:6	Function of input DE3: Brief operation of DHW circulation pump (push-button function). Setting of DHW circulation pump runtime: Coding address 3d
3d:5	DHW circulation pump runtime for brief operation: 5 min	3d:1 to 3d:60	DHW circulation pump runtime adjustable from 1 to 60 min
4b:0	Not assigned	4b:1	External demand
		4b:2	External blocking

General (cont.)

Coding in the delivered condition		Possible change	
51:0	Only if the low loss header sensor is connected: Boiler circuit pump (output A1/21) always runs.	51:1	Do not adjust.
		51:2	When there is demand, the boiler circuit pump only starts if the burner is operational. Note <i>The boiler circuit pump runs on after the burner has stopped.</i>
52:0	Without low loss header sensor	52:1	With low loss header sensor (automatic recognition)
53:0	Function, connection A1 at internal H1 extension (accessories): Central fault message		
54:0	Without solar thermal system	54:1	With Vitosolic 100 (automatic recognition)
		54:2	With Vitosolic 200 (automatic recognition)
		54:4	With solar control module SM1 with auxiliary function, e.g. central heating backup (automatic recognition)
6E:50	No correction of measured outside temperature	6E:0 to 6E:100	Outside temperature correction in 0.1 K steps 0 to 49 = -5 K to -0.1 K 51 to 100 = 0.1 K to 5 K
76:0	Without LON communication module	76:1	With LON communication module (automatic recognition)
77:1	LON subscriber number, if LON communication module is installed	77:2 to 77:99	LON subscriber number, adjustable from 1 to 99: 1 = Boiler 2 - 9 = Do not adjust 10 - 98 = Vitotronic 200-H 99 = Vitocom Note <i>Allocate each number only once.</i>
79:1	With LON communication module: Control unit is fault manager.	79:0	Control unit is not fault manager.
7b:1	With LON communication module: Control unit transmits the time.	7b:0	No time transmission.
7F:1	Detached house	7F:0	Apartment building Holiday program and time program for DHW heating can be set separately
80:6	A fault message is issued if the fault lasts for at least 30 s.	80:0	Immediate fault message
		80:2 to 80:199	Minimum fault duration until fault message occurs, adjustable from 10 s to 995 s; 1 step \triangleq 5 s
81:1	Automatic summer/wintertime changeover	81:0	Manual summer/wintertime changeover
		81:2	Use of the radio clock receiver (automatic recognition)

General (cont.)

Coding in the delivered condition		Possible change	
		81:3	With LON communication module: Control unit receives the time.
82:0	Operation with natural gas	82:1	Operation with LPG (only adjustable if coding address 11:9 has been set)
86:	Do not adjust.		
87:	Do not adjust.		
88:0	Temperature displayed in °C (Celsius)	88:1	Temperature displayed in °F (Fahrenheit)
8A:175	Do not adjust!		
8F:0	All controls active	8F:1	All controls disabled
		8F:2	Only standard settings can be controlled
90:128	Time constant for calculating the changed outside temperature 21.3 h	90:1 to 90:199	Subject to the set value, the flow temperature is adjusted quickly (lower values) or slowly (higher values) when the outside temperature changes. 1 step \pm 10 min
94:0	Do not adjust.		
95:0	Do not adjust.		
97:0	With LON communication module: The outside temperature of the sensor connected to the control unit is used internally.	97:1	Control unit receives outside temperature.
		97:2	The control unit transmits the outside temperature to the LON subscribers.
98:1	Viessmann system number (in conjunction with monitoring of several systems via Vitocom 300)	98:1 to 98:5	System no. adjustable from 1 to 5
99:0	Do not adjust.		
9A:0	Do not adjust.		
9b:70	Set flow temperature for external demand 70 °C	9b:0 to 9b:127	Set flow temperature for external demand adjustable from 0 to 127 °C (limited by boiler-specific parameters)
9C:20	Monitoring LON subscribers. If there is no response from a subscriber for 20 min, the values specified in the control unit are used. Only then will a fault message be issued.	9C:0	No monitoring
		9C:5 to 9C:60	Time adjustable from 5 to 60 min
9F:8	Differential temperature 8 K; only in conjunction with a heating circuit with mixer	9F:0 to 9F:40	Differential temperature adjustable from 0 to 40 K

Boiler

Coding

Coding in the delivered condition		Possible change	
04:1	Minimum burner pause time subject to the boiler load (specified by coding card)	04:0	Minimum burner pause time set permanently (specified by coding card)
06:...	Maximum limit of boiler water temperature, specified in °C by coding card	06:20 to 06:127	Maximum limit of boiler water temperature within the ranges specified by the boiler
0d:0	Do not adjust.		
0E:0	Do not adjust.		
13:1	Do not adjust.		
14:1	Do not adjust.		
15:1	Do not adjust.		
21:0	No service interval set (in hours run)	21:1 to 21:100	The number of hours run before the burner should be serviced is adjustable from 100 to 10,000 h One adjusting step $\hat{=}$ 100 h
23:0	No time set for burner service interval	23:1 to 23:24	Interval adjustable from 1 to 24 months
24:0	"Service" not shown on the display	24:1	"Service" is shown on the display (address is automatically set and must be manually reset after a service has been carried out)
28:0	No burner interval ignition	28:1 to 28:24	Time interval adjustable from 1 h to 24 h. The burner is force-started for 30 s at a time (only when operating with LPG).
2E:0	Do not adjust.		
2F:0	Do not adjust.		
38:0	Burner control unit status: Operational (no fault)	38:≠0	Burner control unit status: Fault

DHW

Coding

Coding in the delivered condition		Possible change	
56:0	Set DHW temperature adjustable from 10 to 60 °C	56:1	Set DHW temperature adjustable from 10 to above 60 °C Note Maximum value subject to boiler coding card. Observe the maximum permissible DHW temperature.
58:0	Without auxiliary function for DHW heating	58:10 to 58:60	Input of a second set DHW temperature, adjustable from 10 to 60 °C (observe coding addresses "56" and "63")

DHW (cont.)

Coding in the delivered condition		Possible change	
59:0	Cylinder heating: Start point -2.5 K Stop point +2.5 K	59:1 to 59:10	Start point adjustable from 1 to 10 K below set value
5E:0	Circulation pump for cylinder heating stays in control mode at "External blocking" signal.	5E:1	Circulation pump for cylinder heating is switched off at "External blocking" signal.
		5E:2	Circulation pump for cylinder heating is switched on at "External blocking" signal.
5F:0	Circulation pump for cylinder heating stays in control mode at "External demand" signal.	5F:1	Circulation pump for cylinder heating is switched off at "External demand" signal.
		5F:2	Circulation pump for cylinder heating is switched off at "External demand" signal.
60:20	During DHW heating, the set boiler water temperature is max. 20 K higher than the set DHW temperature.	60:5 to 60:25	The differential between the set boiler water temperature and the set DHW temperature is adjustable from 5 to 25 K
62:2	Circulation pump for cylinder heating with 2 min run-on time after cylinder heating	62:0	Circulation pump for cylinder heating without run-on
		62:1 to 62:15	Run-on time adjustable from 1 to 15 min
65:0	Without diverter valve		
67:40	For solar DHW heating: Set DHW temperature 40 °C. Reheating is suppressed above the selected set temperature.	67:0 to 67:95	Set DHW temperature adjustable from 0 to 95 °C (limited by boiler-specific parameters)
6F:...	Max. heating output for DHW heating in %, specified by coding card	6F:0 to 6F:100	Max. heating output for DHW heating adjustable from min. heating output to 100 %
71:0	DHW circulation pump: "ON" according to time program	71:1	"OFF" during DHW heating to set value 1
		71:2	"ON" during DHW heating to set value 1
72:0	DHW circulation pump: "ON" according to time program	72:1	"OFF" during DHW heating to set value 2
		72:2	"ON" during DHW heating to set value 2
73:0	DHW circulation pump: "ON" according to time program	73:1 to 73:6	"ON" from once per hour for 5 min up to 6 times per hour for 5 min during the time program
		73:7	Constantly "ON"

Solar**Note**

The solar group is only displayed if a solar control module, type SM1, is connected.

Coding

Coding in the delivered condition		Possible change	
Not allocated to any function mode			
00:8	The solar circuit pump starts if the collector temperature exceeds the actual cylinder temperature by 8 K.	00:2 to 00:30	The differential between the actual cylinder temperature and the start point for the solar circuit pump is adjustable from 2 to 30 K.
01:4	The solar circuit pump is switched off if the differential between the collector temperature and the actual cylinder temperature is less than 4 K.	01:1 to 01:29	The differential between the actual cylinder temperature and the stop point for the solar circuit pump is adjustable from 1 to 29 K.
02:...	Coding dependent on the software version of solar control module SM1	02:0	Solar circuit pump not speed controlled
		02:1	With wave packet control function Do not adjust!
		02:2	Solar circuit pump speed controlled with PWM control
03:10	The temperature differential between the collector temperature and actual cylinder temperature is regulated to 10 K.	03:5 to 03:20	The differential temperature control between collector temperature and actual cylinder temperature is adjustable from 5 to 20 K.
04:4	Controller amplification of speed control 4 %/K	04:1 to 04:10	Controller amplification adjustable from 1 to 10 %/K
05:10	Min. speed of the solar circuit pump 10 % of max. speed	05:2 to 05:100	Min. speed of solar circuit pump adjustable from 2 to 100 %.
06:75	Max. speed of the solar circuit pump 75 % of max. possible speed	06:2 to 06:100	Max. speed of solar circuit pump adjustable from 2 to 100 %.
07:0	Interval function of solar circuit pump switched off	07:1	Interval function of solar circuit pump switched on To measure the collector temperature more accurately, the solar circuit pump periodically starts for a short duration.
08:60	The solar circuit pump is stopped if the actual cylinder temperature reaches 60 °C (maximum cylinder temperature).	08:10 to 08:90	The maximum cylinder temperature is adjustable from 10 to 90 °C.
09:130	The solar circuit pump is stopped if the collector temperature reaches 130 °C (maximum collector temperature to protect the system components)	09:20 to 09:200	The temperature is adjustable from 20 to 200 °C.
0A:5	To protect the system components and heat transfer medium, the speed of the solar circuit pump is reduced if the differential between the actual cylinder temperature and the set cylinder temperature is less than 5 K.	0A:0 to 0A:40	The differential between the set cylinder temperature and the start point for reducing the stagnation time is adjustable from 0 to 40 K.

Solar (cont.)

Coding in the delivered condition		Possible change	
0b:0	Collector frost protection function switched off	0b:1	Collector frost protection function switched on (not required with Viessmann heat transfer medium).
0C:1	Delta T monitoring switched on No flow rate detected in the collector circuit or flow rate too low.	0C:0	Delta T monitoring switched off
0d:1	Night DHW circulation monitoring switched on Unintentional flow rate in the collector circuit is captured (e.g. at night).	0d:0	Night DHW circulation monitoring switched off
0E:1	Calculation of solar yield with Viessmann heat transfer medium	0E:2	Calculation of solar yield with water as heat transfer medium (do not select as operation is only possible with Viessmann heat transfer medium)
		0E:0	Calculation of solar yield switched off
0F:70	The flow rate in the collector circuit at the maximum pump speed is set to 7 l/min.	0F:1 to 0F:255	Flow rate in the collector circuit adjustable from 0.1 to 25.5 l/min
10:0	Target temperature control switched off (see coding address 11)	10:1	Target temperature control switched on
11:50	Set solar cylinder temperature 50 °C <ul style="list-style-type: none"> ▪ Target temperature control switched on (code 10:1): Temperature at which the solar heated water is to be stratified into the DHW cylinder. ▪ Extended control functions set to heat two DHW cylinders (code 20:9): When the actual temperature of the DHW cylinder reaches the set cylinder temperature, heating is switched over to the 2nd DHW cylinder. 	11:10 to 11:90	The set solar cylinder temperature is adjustable from 10 to 90 °C.
12:20	Minimum collector temperature 20 °C The solar circuit pump is only started when the set minimum collector temperature is exceeded at the collector temperature sensor.	12:0	Minimum collector temperature function switched off
		12:1 to 12:90	The minimum collector temperature is adjustable from 1 to 90 °C.

Coding in the delivered condition		Possible change	
20:0	No extended control function active	20:1	Auxiliary function for DHW heating
		20:2	Differential temperature control 2
		20:3	Differential temperature control 2 and auxiliary function
		20:4	Differential temperature control 2 for central heating backup
		20:5	Thermostat function
		20:6	Thermostat function and auxiliary function
		20:7	Solar heating via external heat exchanger without additional temperature sensor
		20:8	Solar heating via external heat exchanger with additional temperature sensor
		20:9	Solar heating of 2 DHW cylinders
22:8	Start temperature differential for central heating backup: 8 K Switching output <input type="checkbox"/> 22 is switched on if the temperature at sensor <input type="checkbox"/> 7 has exceeded the temperature at sensor <input type="checkbox"/> 10 by the selected value.	22:2 to 22:30	Start temperature differential for central heating backup is adjustable from 2 to 30 K.
23:4	Stop temperature differential for central heating backup: 4 K Switching output <input type="checkbox"/> 22 is switched off if the temperature at sensor <input type="checkbox"/> 7 undershoots the stop point. The stop point is the sum of the temperature at sensor <input type="checkbox"/> 10 and the value selected as stop temperature differential.	23:2 to 23:30	Stop temperature differential for central heating backup is adjustable from 1 to 29 K.
24:40	Start temperature for the thermostat function 40 °C. Start temperature for thermostat function \leq stop temperature for thermostat function: Thermostat function e.g. for reheating. Switching output <input type="checkbox"/> 22 is switched on if the temperature at sensor <input type="checkbox"/> 7 undershoots the start temperature for the thermostat function. Start temperature for thermostat function $>$ stop temperature for thermostat function: Thermostat function e.g. for utilising excess heat. Switching output <input type="checkbox"/> 22 is switched on if the temperature at sensor <input type="checkbox"/> 7 exceeds the start temperature for the thermostat function.	24:0 to 24:100	Start temperature for thermostat function is adjustable from 0 to 100 K.

Solar (cont.)

Coding in the delivered condition		Possible change	
25:50	<p>Stop temperature for the thermostat function 50 °C. Start temperature for thermostat function \leq stop temperature for thermostat function: Thermostat function e.g. for re-heating. Switching output $\square{22}$ is switched off if the temperature at sensor $\square{7}$ exceeds the start temperature for the thermostat function.</p> <p>Start temperature for thermostat function $>$ stop temperature for thermostat function: Thermostat function e.g. for utilising excess heat. Switching output $\square{22}$ is switched off if the temperature at sensor $\square{7}$ undershoots the start temperature for the thermostat function.</p>	25:0 to 25:100	Start temperature for thermostat function is adjustable from 0 to 100 K.
26:1	Priority for DHW cylinder 1 – with cyclical heating Only when setting code 20:9.	26:0	Priority for DHW cylinder 1 – without cyclical heating
		26:2	Priority for DHW cylinder 2 – without cyclical heating
		26:3	Priority for DHW cylinder 2 – with cyclical heating
		26:4	Cyclical heating without priority for one of the DHW cylinders
27:15	Cyclical heating time 15 min. If the DHW cylinder with priority has been heated up, the DHW cylinder without priority is heated for a maximum duration equal to the set cyclical heating time.	27:5 to 27:60	Cyclical heating time is adjustable from 5 to 60 min.
28:3	Cyclical pause time 3 min. After the set cyclical heating time for the DHW cylinder without priority has expired, the rise in collector temperature is detected during the cyclical pause time.	28:1 to 28:60	Cyclical pause time adjustable from 1 to 60 min.

Heating circuit 1, heating circuit 2, heating circuit 3**Coding**

Coding in the delivered condition		Possible change	
A0:0	Without remote control	A0:1	With Vitotrol 200-A/200-RF (automatic recognition).
		A0:2	With Vitotrol 300-A (automatic recognition).
A1:0	All settings available on the remote control can be adjusted.	A1:1	Only party mode can be set at the remote control. (Only on Vitotrol 200-A.)

Heating circuit 1, heating circuit 2, heating... (cont.)

Coding in the delivered condition		Possible change	
A2:2	Cylinder priority for heating circuit pump	A2:0	No cylinder priority for heating circuit pump
		A2:1	Cylinder priority for mixer. The mixer is closed during cylinder heating. The heating circuit pump is running.
		A2:3 to A2:15	Modulating priority for mixers. The heating circuit receives a reduced amount of heat.
A3:2	Outside temperature below 1 °C: Heating circuit pump "ON" Outside temperature above 3 °C: Heating circuit pump "OFF"	A3:9 to A3:15	Heating circuit pump "ON/OFF" (see the following table)

- !** **Please note**
 With settings below 1 °C there is a risk that pipes outside the thermal envelope of the building could freeze up.
 Standby mode in particular must be taken into consideration, e.g. during holidays.

Parameter address A3:...	Heating circuit pump	
	"ON"	"OFF"
-9	-10 °C	-8 °C
-8	-9 °C	-7 °C
-7	-8 °C	-6 °C
-6	-7 °C	-5 °C
-5	-6 °C	-4 °C
-4	-5 °C	-3 °C
-3	-4 °C	-2 °C
-2	-3 °C	-1 °C
-1	-2 °C	0 °C
0	-1 °C	1 °C
1	0 °C	2 °C
2 to 15	1 °C to 14 °C	3 °C to 16 °C

Coding in the delivered condition		Possible change	
A4:0	With frost protection	A4:1	No frost protection; this setting is only possible if code "A3:-9" has been set. Note <i>Important – please note for code "A3".</i>
A5:5	With heating circuit pump logic function (economy mode): Heating circuit pump "OFF" when outside temperature (OT) is 1 K higher than set room temperature (RT _{set}) OT > RT _{set} + 1 K	A5:0	Without heating circuit pump logic function
		A5:1 to A5:15	With heating circuit pump logic function: Heating circuit pump "OFF" (see the following table)

Heating circuit 1, heating circuit 2, heating... (cont.)

Parameter address A5:...	With heating circuit pump logic function: Heating circuit pump "OFF"
1	$OT > RT_{set} + 5 K$
2	$OT > RT_{set} + 4 K$
3	$OT > RT_{set} + 3 K$
4	$OT > RT_{set} + 2 K$
5	$OT > RT_{set} + 1 K$
6	$OT > RT_{set}$
7	$OT > RT_{set} - 1 K$
to	
15	$OT > RT_{set} - 9 K$

Coding in the delivered condition		Possible change	
A6:36	Extended economy mode not active	A6:5 to A6:35	Extended economy mode enabled, i.e. the burner and heating circuit pump are switched off at a variable value, adjustable from 5 to 35 °C plus 1 °C. Mixer is being closed. The basis for this is the adjusted outside temperature. This is derived from the actual outside temperature and a time constant that takes account of the way an average building cools down.
A7:0	Without mixer economy function (only for heating circuits with mixer)	A7:1	With mixer economy function (extended heating circuit pump logic): Heating circuit pump also "OFF": <ul style="list-style-type: none"> ▪ If the mixer has been trying to close for more than 20 min. Heating circuit pump "ON": <ul style="list-style-type: none"> ▪ If the mixer changes to control function ▪ If there is a risk of frost
A9:7	With pump idle time: Heating circuit pump "OFF" if set value is modified by changing the operating mode or changing the set room temperature	A9:0	Without pump idle time
		A9:1 to A9:15	With pump idle time, adjustable from 1 to 15
b0:0	With remote control: Heating mode/reduced. Operation: Weather-compensated (change code only for the heating circuit with mixer)	b0:1	Heating mode: Weather-compensated Reduced mode: With room temperature hook-up
		b0:2	Heating mode: With room temperature hook-up Reduced mode: Weather-compensated
		b0:3	Heating mode/reduced mode: With room temperature hook-up
b2:8	With remote control and for the heating circuit, operation with room temperature hook-up must be programmed: Room influence factor 8 (only change the code for the heating circuit with mixer)	b2:0	Without room influence

Heating circuit 1, heating circuit 2, heating... (cont.)

Coding in the delivered condition		Possible change	
		b2:1 to b2:64	Room influence factor adjustable from 1 to 64
b5:0	With remote control: No room temperature-dependent heating circuit pump logic function (change code only for heating circuit with mixer)	b5:1 to b5:8	For heating circuit pump logic function, see the following table:

Parameter address b5:...	With heating circuit pump logic function:	
	Heating circuit pump "OFF"	Heating circuit pump "ON"
1	$RT_{\text{actual}} > RT_{\text{set}} + 5 \text{ K}$	$RT_{\text{actual}} < RT_{\text{set}} + 4 \text{ K}$
2	$RT_{\text{actual}} > RT_{\text{set}} + 4 \text{ K}$	$RT_{\text{actual}} < RT_{\text{set}} + 3 \text{ K}$
3	$RT_{\text{actual}} > RT_{\text{set}} + 3 \text{ K}$	$RT_{\text{actual}} < RT_{\text{set}} + 2 \text{ K}$
4	$RT_{\text{actual}} > RT_{\text{set}} + 2 \text{ K}$	$RT_{\text{actual}} < RT_{\text{set}} + 1 \text{ K}$
5	$RT_{\text{actual}} > RT_{\text{set}} + 1 \text{ K}$	$RT_{\text{actual}} < RT_{\text{set}}$
6	$RT_{\text{actual}} > RT_{\text{set}}$	$RT_{\text{actual}} < RT_{\text{set}} - 1 \text{ K}$
7	$RT_{\text{actual}} > RT_{\text{set}} - 1 \text{ K}$	$RT_{\text{actual}} < RT_{\text{set}} - 2 \text{ K}$
8	$RT_{\text{actual}} > RT_{\text{set}} - 2 \text{ K}$	$RT_{\text{actual}} < RT_{\text{set}} - 3 \text{ K}$

Coding in the delivered condition		Possible change	
C5:20	Electronic minimum flow temperature limit 20 °C	C5:1 to C5:127	Minimum limit adjustable from 1 to 127 °C (limited by boiler-specific parameters)
C6:74	Electronic maximum flow temperature limit set to 90 °C	C6:10 to C6:127	Maximum limit adjustable from 10 to 127 °C (limited by boiler-specific parameters)
d3:14	Heating curve slope = 1.4	d3:2 to d3:35	Heating curve slope adjustable from 0.2 to 3.5 (see page 28)
d4:0	Heating curve level = 0	d4:-13 to d4:40	Heating curve level adjustable from -13 to 40 (see page 28)
d5:0	External operating program changeover switches the operating program to "Constant operation at reduced room temperature" or "Standby mode"	d5:1	The external operating program changeover switches to "Continuous operation at standard room temperature" (subject to coding address 3A, 3b and 3C)
d6:0	Heating circuit pump stays in control mode at "External blocking" signal.	d6:1	Heating circuit pump is switched off at "External blocking" signal (subject to coding addresses 3A, 3b and 3C)
		d6:2	Heating circuit pump is switched off at "External blocking" signal (subject to coding addresses 3A, 3b and 3C)
d7:0	Heating circuit pump stays in control mode at "External demand" signal.	d7:1	Heating circuit pump is switched off at "External demand" signal (subject to coding addresses 3A, 3b and 3C)
		d7:2	Heating circuit pump is switched off at "External demand" signal (subject to coding addresses 3A, 3b and 3C)
d8:0	No operating program changeover via EA1 extension	d8:1	Operating program changeover via input DE1 at EA1 extension

Heating circuit 1, heating circuit 2, heating... (cont.)

Coding in the delivered condition		Possible change	
		d8:2	Operating program changeover via input DE2 at EA1 extension
		d8:3	Operating program changeover via input DE3 at EA1 extension
E1:1	Do not adjust.		
E2:50	With remote control: No display correction of the actual room temperature	E2:0 to E2:49	Display correction -5 K to Display correction -0.1 K
		E2:51 to E2:99	Display correction +0.1 K to Display correction +4.9 K
E5:0	Do not adjust.		
F1:0	Screed drying not active.	F1:1 to F1:6	Screed drying adjustable in accordance with 6 selectable temperature/time profiles (see page 85)
		F1:15	Constant flow temperature 20 °C
F2:8	Time limit for party mode or external operating program changeover via pushbutton: 8 h	F2:0	No time limit for party mode
		F2:1 to F2:12	Time limit adjustable from 1 to 12 h
F8:-5	Temperature limit for terminating reduced mode -5 °C; see example on page 87. Observe setting of coding address "A3".	F8:+10 to F8:-60	Temperature limit adjustable from +10 to -60 °C
		F8:-61	Function inactive
F9:-14	Temperature limit for raising the reduced set room temperature -14 °C; see example on page 87.	F9:+10 to F9:-60	Limit for raising the set room temperature to the value selected for standard mode adjustable from +10 to -60 °C
FA:20	Set boiler water temperature or set flow temperature is raised by 20 % when switching from operation with reduced room temperature to operation with standard room temperature. See example on page 87.	FA:0 to FA:50	Temperature increase adjustable from 0 to 50 %
Fb:30	Duration for raising the set boiler water or flow temperature (see coding address "FA") 60 min. See example on page 87.	Fb:0 to Fb:150	Duration adjustable from 0 to 300 min 1 step \pm 2 min

Calling up the service menu

Press **OK** and **≡** simultaneously for approx. 4 s.

Service menu overview

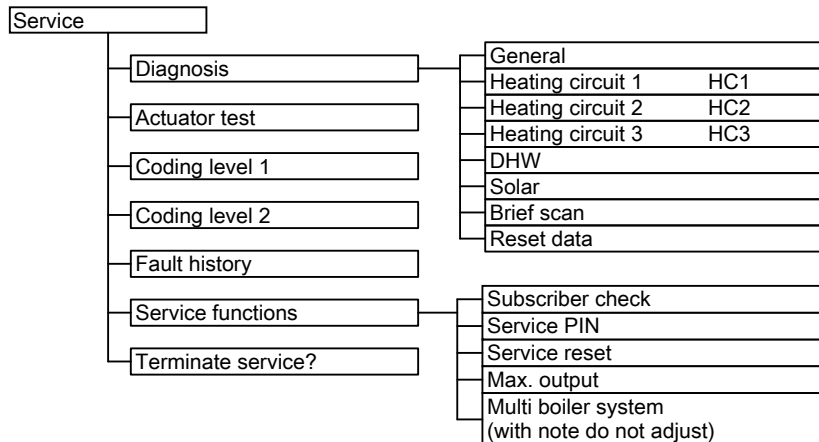

Fig. 21

Diagnosis

Checking operating data

Operating data can be called up in 6 areas. See **"Diagnosis"** in the service menu overview.

Operating data on heating circuits with mixer or solar thermal systems can only be called up if such components are present in the system.

For further information on operating data, see chapter **"Brief scan"**.

Note

If a called up sensor is faulty, **"- - -"** appears on the display.

Calling up operating data

1. Press **OK** and **≡** simultaneously for approx. 4 s.
2. **"Diagnosis"**

3. Select the required group, e.g. **"General"**.

Resetting operating data

Saved operating data (e.g. hours run) can be reset to 0.

The value **"Adjusted outside temp"** is reset to the actual value.

1. Press **OK** and **≡** simultaneously for approx. 4 s.
2. **"Diagnosis"**
3. **"Reset data"**
4. Select required value (e.g. **"Burner starts"**) or **"All details"**.

Brief scan

In the brief scan, you can call up temperatures, software versions and connected components, for example.

1. Press **OK** and **≡** simultaneously for approx. 4 s.
2. **"Diagnosis"**
3. **"Brief scan"**.

4. Press **OK**.
The display shows 9 rows with 6 fields each.

Diagnosis Brief scan					
1:	1	F	0	A	1 2
2:	0	0	0	0	0 0
3:	0	0	0	0	0 0
4:	0	0	0	0	0 0

Select with **◀▶**

Fig. 22

Diagnosis (cont.)

For an explanation of the relevant values in the individual rows and fields, see the following table:

Row (brief scan)	Field					
	1	2	3	4	5	6
1:	System scheme 01 to 10		Software version Control unit		Software version Programming unit	
2:	0	0	Appliance version		Appliance ID (CU-ID)	
3:	0	0	Number of KM-BUS subscribers		Software version, solar control module SM1	
4:	Software version Burner control unit		Type Burner control unit		Version, burner control unit	
5:	Internal details for calibration				0	Software version, EA1 extension 0 = No EA1
6:	0	0	0	0	0	0
7:	LON Subnet address/system number		LON Node address		0	0
8:	LON SBVT configuration	LON Software version, communication coprocessor	LON Neuron chip software version		Number of LON subscribers	
9:	Heating circuit A1/HC1 Remote control 0: None 1: Vitotrol 200-A/ 200-RF 2: Vitotrol 300-A		Heating circuit M2/HC2 Remote control 0: None 1: Vitotrol 200-A/ 200-RF 2: Vitotrol 300-A		Heating circuit M3/HC3 Remote control 0: None 1: Vitotrol 200-A/ 200-RF 2: Vitotrol 300-A	
11:	0	0	Software version Mixer extension, heating circuit M2 0: No mixer extension	0	Software version Mixer extension, heating circuit M3 0: No mixer extension	0

Checking outputs (actuator test)

1. Press **OK** and  simultaneously for approx. 4 s.
2. **"Actuator test"**

The following relay outputs can be controlled subject to the system equipment level:

Display		Explanation
"All actuators"	OFF	All actuators are off.
"Base load"	ON	Burner operates at minimum output; heating circuit pump A1 is on.
"Full load"	ON	Burner operates at maximum output; heating circuit pump A1 is on.
"Output, internal"	ON	Internal output  (cylinder loading pump) enabled

Checking outputs (actuator test) (cont.)

Display		Explanation
"Htg circ pump HC2"	ON	Output for heating circuit pump active (extension heating circuit with mixer)
"Mixer HC2"	Open	Output for "Mixer open" active (extension heating circuit with mixer)
"Mixer HC2"	Close	Output for "Mixer close" active (extension heating circuit with mixer)
"Htg circ pump HC3"	ON	Output for heating circuit pump active (extension heating circuit with mixer)
"Mixer HC3"	Open	Output for "Mixer open" active (extension heating circuit with mixer)
"Mixer HC3"	Close	Output for "Mixer close" active (extension heating circuit with mixer)
"Outp. int. exten. H1"	ON	Output at internal H1/H2 extension enabled
"EA1 output 1"	ON	Contact P - S at plug 157 of EA1 extension closed
"Solar circuit pump"	ON	Solar circuit pump output 24 on solar control module SM1 active
"Solar circ pmp min"	ON	Solar circuit pump output on solar control module SM1 switched to minimum speed
"Solar circ pmp max"	ON	Solar circuit pump output on solar control module SM1 switched to maximum speed
"Sol. output 22"	ON	Output 22 on solar control module SM1 active
"SA 104 output 1"	ON	Output for DHW circulation pump 28
"SA 104 output 2"	ON	Output for heating circuit pump A1 20

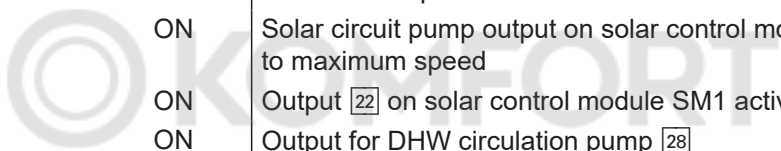

Fault display

In the event of a fault, red fault indicator **A** flashes. "▲" flashes on the display and "Fault" is shown.

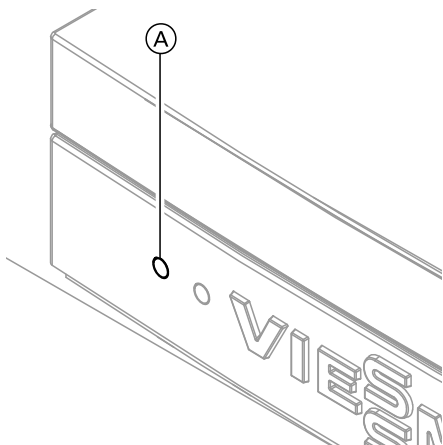

Fig. 23

Press **OK** to display the fault code. For an explanation of the fault code, see the following pages. For some faults, the type of fault is also displayed in plain text.

Acknowledging a fault

Follow the instructions on the display.

Note

The fault message is shown on the default display of the short menu.

Any fault message facility connected will be switched off.

If an acknowledged fault is not remedied, the fault message will be redisplayed the following day and the fault message facility restarted.

Calling up acknowledged faults

In the standard menu, select "Fault". Current faults will be listed.

Calling up fault codes from the fault memory (fault history)

The 10 most recent faults (including those remedied) are saved and can be called up. Faults are sorted by date.

1. Press **OK** and **≡** simultaneously for approx. 4 s.
2. "Fault history"
3. "Display?"

Deleting the fault history

1. Press **OK** and **≡** simultaneously for approx. 4 s.
2. "Fault history"
3. "Delete?"

Fault codes

10

System characteristics

Regulates as if the outside temperature were 0 °C.

Cause

Short circuit, outside temperature sensor

Measures

Check outside temperature sensor (see page 72).

18

System characteristics

Regulates as if the outside temperature were 0 °C.

Cause

Lead break, outside temperature sensor

Measures

Check outside temperature sensor (see page 72).

Troubleshooting

Fault codes (cont.)

19

System characteristics

Regulates as if the outside temperature were 0 °C.

Cause

Configuration fault

Measures

Set code 2A:0.

30

System characteristics

Burner locked out

Cause

Short circuit, boiler water temperature sensor

Measures

Check the boiler water temperature sensor (see page 73)

38

System characteristics

Burner locked out

Cause

Lead break, boiler water temperature sensor

Measures

Check the boiler water temperature sensor (see page 73)

40

System characteristics

Mixer is being closed.

Cause

Short circuit, flow temperature sensor, heating circuit 2 (with mixer)

Measures

Check flow temperature sensor.

44

System characteristics

Mixer is being closed.

Cause

Short circuit, flow temperature sensor, heating circuit 3 (with mixer)

Measures

Check flow temperature sensor.

48

System characteristics

Mixer is being closed.

58



Fault codes (cont.)

Cause

Lead break, flow temperature sensor, heating circuit 2 (with mixer)

Measures

Check flow temperature sensor.

4C

System characteristics

Mixer is being closed.

Measures

Check flow temperature sensor.

Cause

Lead break, flow temperature sensor, heating circuit 3 (with mixer)

50

System characteristics

No DHW heating

Measures

Check sensors (see page 73).

Cause

Short circuit, cylinder temperature sensor

58

System characteristics

No DHW heating

Measures

Check sensors (see page 73).

Cause

Lead break, cylinder temperature sensor

90

System characteristics

Normal operation

Measures

Check sensor 7 on the solar control module.

Cause

Short circuit, temperature sensor 7

91

System characteristics

Normal operation

Measures

Check sensor 10 on the solar control module.

Cause

Short circuit, temperature sensor 10

Fault codes (cont.)

92	
System characteristics	Measures
No solar DHW heating	Check temperature sensor [6] on the solar control module or the sensor on the Vitosolic.
Cause	
Short circuit, collector temperature sensor	

93	
System characteristics	Measures
Normal operation	Check temperature sensor at connection S3 on the Vitosolic 100.
Cause	
Short circuit, cylinder temperature sensor	

94	
System characteristics	Measures
No solar DHW heating	Check temperature sensor [5] on the solar control module or the sensor on the Vitosolic.
Cause	
Short circuit, cylinder temperature sensor	

98	
System characteristics	Measures
Normal operation	Check sensor [7] on the solar control module.
Cause	
Lead break, temperature sensor [7]	

99	
System characteristics	Measures
Normal operation	Check sensor [10] on the solar control module.
Cause	
Lead break, temperature sensor [10]	

9A	
System characteristics	Cause
No solar DHW heating	Lead break, collector temperature sensor



Fault codes (cont.)

Measures

Check temperature sensor [6] on the solar control module or the sensor on the Vitosolic.

9b

System characteristics

Normal operation

Cause

Lead break, cylinder temperature sensor

Measures

Check temperature sensor at connection S3 on the Vitosolic 100.

9C

System characteristics

No solar DHW heating

Cause

Lead break, cylinder temperature sensor

Measures

Check temperature sensor [5] on the solar control module or the sensor on the Vitosolic.

9E

System characteristics

Normal operation

Cause

No flow rate or inadequate flow rate in collector circuit, or temperature limiter has responded.

Measures

Check solar circuit pump and solar circuit. Acknowledge fault message.

9F

System characteristics

Normal operation

Cause

Solar control module or Vitosolic fault

Measures

Replace solar control module or Vitosolic.

A3

System characteristics

Burner locked out.

Cause

Flue gas temperature sensor incorrectly positioned.

Measures

Fit flue gas temperature sensor correctly. See page 74

Fault codes (cont.)

A7

System characteristics

Normal operation as per delivered condition

Measures

Replace the programming unit.

Cause

Programming unit faulty

b0

System characteristics

Burner locked out

Measures

Check flue gas temperature sensor.

Cause

Short circuit, flue gas temperature sensor

b1

System characteristics

Normal operation as per delivered condition

Measures

Check connections and replace programming unit if necessary.

Cause

Communication error, programming unit

b5

System characteristics

Normal operation as per delivered condition

Measures

Replace control unit.

Cause

Internal fault

b7

System characteristics

Burner locked out

Measures

Plug in coding card or replace if faulty.

Cause

Coding card fault

b8

System characteristics

Burner locked out

Cause

Lead break, flue gas temperature sensor



Fault codes (cont.)

Measures

Check flue gas temperature sensor.

bA

System characteristics

Mixer regulates to 20 °C flow temperature

Measures

Check extension kit connections and code.

Cause

Communication error, extension kit for heating circuit 2 (with mixer)

bb

System characteristics

Mixer regulates to 20 °C flow temperature

Measures

Check extension kit connections and code.

Cause

Communication error, extension kit for heating circuit 3 (with mixer)

bC

System characteristics

Normal operation without remote control

Measures

Check connections, cable, coding address **"A0"** in the **"Heating circuit"** group and remote control settings (see page 88). For wireless remote control units: Check connection; place remote control close to the boiler.

Cause

Communication error, Vitotrol remote control, heating circuit 1 (without mixer)

bd

System characteristics

Normal operation without remote control

Measures

Check connections, cable, coding address **"A0"** in the **"Heating circuit"** group and remote control settings (see page 88). For wireless remote control units: Check connection; place remote control close to the boiler.

Cause

Communication error, Vitotrol remote control, heating circuit 2 (with mixer)

bE

System characteristics

Normal operation without remote control

Cause

Communication error, Vitotrol remote control, heating circuit 3 (with mixer)

Fault codes (cont.)

Measures

Check connections, cable, coding address **"A0"** in the **"Heating circuit"** group and remote control settings (see page 88). For wireless remote control units: Check connection; place remote control close to the boiler.

bF

System characteristics

Normal operation

Measures

Replace LON communication module.

Cause

Wrong LON communication module

C1

System characteristics

Normal operation

Measures

Check the connections.

Cause

Communication error, EA1 extension

C2

System characteristics

Normal operation

Measures

Check solar control module or Vitosolic.

Cause

Communication error, solar control module or Vitosolic

C3

System characteristics

Normal operation

Measures

Check the connections.

Cause

Communication error AM1

Cd

System characteristics

Normal operation

Measures

Set code 95:0.

Cause

Configuration fault

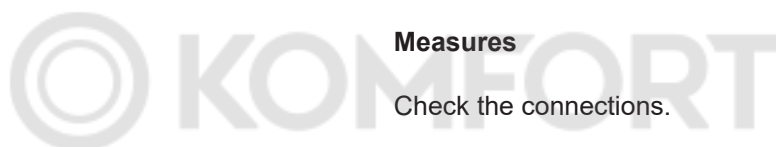

Fault codes (cont.)

CF

System characteristics

Normal operation

Measures

Replace LON communication module.

Cause

Communication error, LON communication module

d6

System characteristics

Normal operation

Measures

Remedy fault at affected appliance.

Cause

Input DE1 at EA1 extension reports a fault.

d7

System characteristics

Normal operation

Measures

Remedy fault at affected appliance.

Cause

Input DE2 at EA1 extension reports a fault.

d8

System characteristics

Normal operation

Measures

Remedy fault at affected appliance.

Cause

Input DE3 at EA1 extension reports a fault.

dA

System characteristics

Normal operation without room influence

Measures

Check room temperature sensor, heating circuit 1.

Cause

Short circuit, room temperature sensor, heating circuit 1 (without mixer)

db

System characteristics

Normal operation without room influence

Cause

Short circuit, room temperature sensor, heating circuit 2 (with mixer)

Fault codes (cont.)

Measures

Check room temperature sensor, heating circuit 2.

dC

System characteristics

Normal operation without room influence

Cause

Short circuit, room temperature sensor, heating circuit 3 (with mixer)

Measures

Check room temperature sensor, heating circuit 3.

dd

System characteristics

Normal operation without room influence

Cause

Lead break, room temperature sensor, heating circuit 1 (without mixer)

Measures

Check room temperature sensor, heating circuit 1 and remote control settings (see page 88)

dE

System characteristics

Normal operation without room influence

Cause

Lead break, room temperature sensor, heating circuit 2 (with mixer)

Measures

Check room temperature sensor, heating circuit 2 and remote control settings (see page 88)

dF

System characteristics

Normal operation without room influence

Cause

Lead break, room temperature sensor, heating circuit 3 (with mixer)

Measures

Check room temperature sensor, heating circuit 3 and remote control settings (see page 88)

E0

System characteristics

Normal operation

Cause

External LON subscriber fault

Measures

Check connections and LON subscribers.



Fault codes (cont.)

E1

System characteristics

Burner in a fault state

Cause

Ionisation current too high during calibration

Measures

Check gap between ionisation electrode and burner gauze assembly (see page 21).

In open flue operation, prevent high levels of dust in the combustion air.

Press reset button **R**.

E3

System characteristics

Burner in a fault state

Cause

Heat transfer too low during calibration.

Temperature limiter has shut down.

Measures

Ensure adequate heat transfer.

Press reset button **R**.

E4

System characteristics

Burner locked out

Cause

24 V power supply fault

Measures

Replace control unit.

E5

System characteristics

Burner locked out

Cause

Flame amplifier fault

Measures

Replace control unit.

E7

System characteristics

Burner in a fault state

Cause

Ionisation current too low during calibration

Measures

Check ionisation electrode for the following:

- Distance to burner gauze assembly (see page 21)
- Contamination on electrode.
- Connecting cable and plug-in connections

Check flue system; remove flue gas recirculation if necessary.

Press reset button **R**.

E8

System characteristics

Burner in a fault state

Cause

Ionisation current lies outside the permissible range

Measures

Check gas supply (gas pressure and gas flow switch), gas solenoid valve and connection line.

Check assignment of gas type (see page 15).

Check ionisation electrode for the following:

- Distance to burner gauze assembly (see page 21)
- Contamination on electrode.

Press reset button **R**.

EA

System characteristics

Burner in a fault state

Cause

Ionisation current not within permissible range during calibration (excessive deviation from previous level)

Measures

Check flue system; remove flue gas recirculation if necessary.

In open flue operation, prevent high levels of dust in the combustion air.

Press reset button **R**.

Following several unsuccessful reset attempts, replace the coding card and press reset button **R**.

Eb

System characteristics

Burner in a fault state

Cause

Repeated flame loss during calibration

Measures

Check gap between ionisation electrode and burner gauze assembly (see page 21).

Check assignment of gas type (see page 15).

Check flue system; remove flue gas recirculation if necessary.

Press reset button **R**.

EC

System characteristics

Burner in a fault state

Cause

Parameter fault during calibration

Measures

Press reset button **R**.

or

Replace coding card and then press reset button **R**.

Ed

System characteristics

Burner in a fault state

Cause

Internal fault

Measures

Replace control unit.

Fault codes (cont.)

EE

System characteristics

Burner in a fault state

Cause

Flame signal is not present or insufficient at burner start

Measures

Check gas supply (gas pressure and gas flow switch).

Check gas solenoid valve.
Check ionisation electrode and connecting cable.

Check ignition:

- Connecting cables to ignition module and ignition electrode
- Ignition electrode gap and contamination (see page 21).

Check condensate drain.
Press reset button **R**.

EF

System characteristics

Burner in a fault state

Cause

Flame is lost immediately after flame formation (during safety time).

Measures

Check gas supply (gas pressure and gas flow switch).

Check balanced flue system for flue gas recirculation.

Check ionisation electrode (replace if required):

- Distance to burner gauze assembly (see page 21)
- Contamination on electrode.

Press reset button **R**.

F0

System characteristics

Burner locked out

Cause

Internal fault

Measures

Replace control unit.

F1

System characteristics

Burner in a fault state

Cause

Flue gas temperature limiter has responded

Measures

Check heating system fill level. Vent the system.
Press reset button **R** after flue system has cooled down.

F2

System characteristics

Burner in a fault state

Cause

Temperature limiter has responded.

Fault codes (cont.)

Measures

Press reset button **R**.

Check heating system fill level. Check circulation pump. Vent the system. Check temperature limiter and connecting cables.

F3

System characteristics

Burner in a fault state

Measures

Check ionisation electrode and connecting cable. Press reset button **R**.

Cause

Flame signal is already present at burner start

F8

System characteristics

Burner in a fault state

Measures

Check gas solenoid valve. Check both control paths. Press reset button **R**.

Cause

Fuel valve closes late.

F9

System characteristics

Burner in a fault state

Measures

Check the fan, fan connecting cables, fan power supply and fan control. Press reset button **R**.

Cause

Fan speed too low at burner start

FA

System characteristics

Burner in a fault state

Measures

Check the fan, fan connecting cables and fan control. Press reset button **R**.

Cause

Fan idle state not reached

FC

System characteristics

Burner in a fault state

Measures

Check gas solenoid valve. Check flue system. Press reset button **R**.

Cause

Gas solenoid valve faulty, modulation valve control faulty or flue gas path blocked



Fault codes (cont.)

Fd

System characteristics

Burner in a fault state and additional fault b7 is displayed.

Cause

Coding card missing.

Measures

Insert coding card.
Press reset button **R**.
Replace control unit if fault persists.

Fd

System characteristics

Burner in a fault state

Cause

Burner control unit fault

Measures

Check ignition electrodes and connecting cables.
Check whether a strong interference (EMC) field exists near the appliance.
Press reset button **R**.
Replace control unit if fault persists.

FE

System characteristics

Burner blocked or in a fault state

Cause

Coding card or main PCB faulty, or incorrect coding card

Measures

Press reset button **R**. If fault persists, check the coding card and replace coding card or control unit if necessary.

FF

System characteristics

Burner blocked or in a fault state

Cause

Internal fault or reset button **R** blocked.

Measures

Restart the appliance. Replace the control unit if the appliance will not restart.

OF

System characteristics

Normal operation

Cause

Set maintenance interval expired.

Measures

Reset the indicator. See chapter "Checking and resetting the service display" on page 30.

Checking the outside temperature sensor

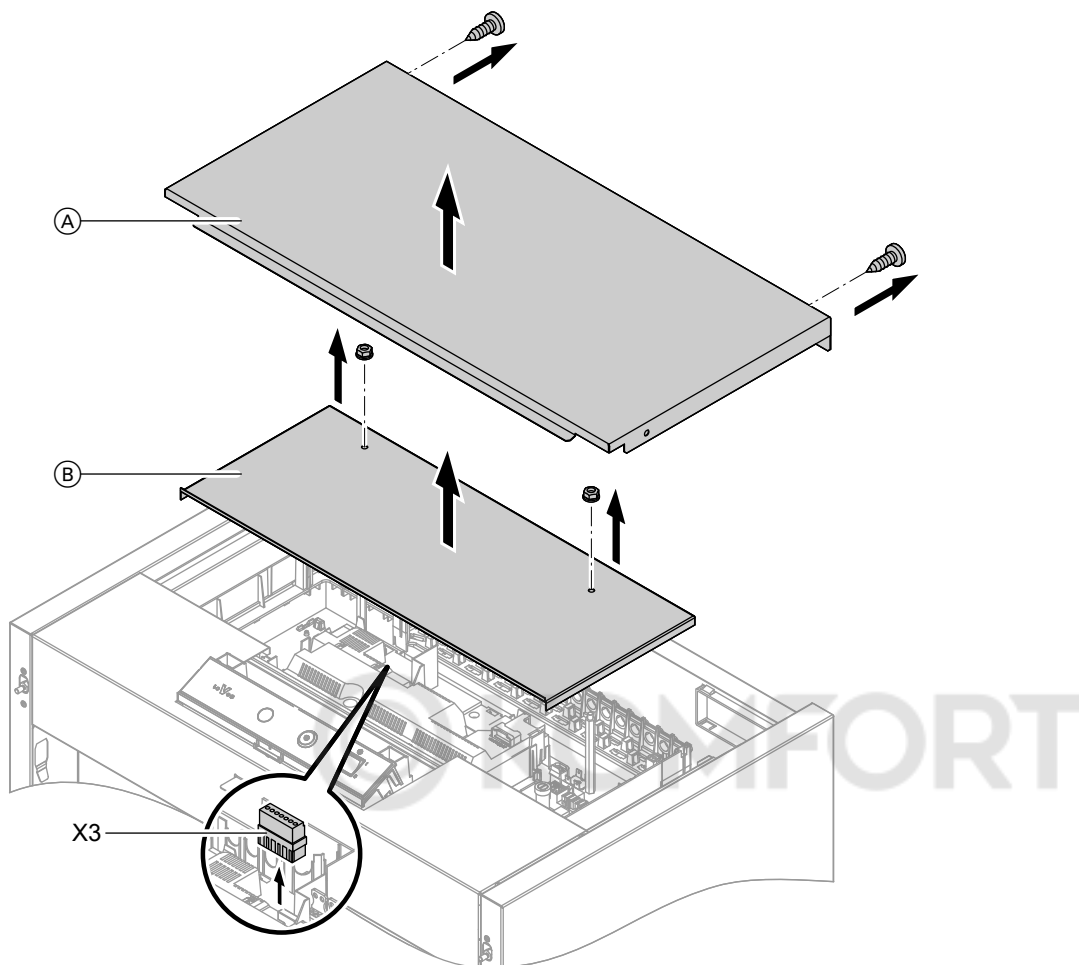

Fig. 24

- (A) Boiler top panel
- (B) Control unit enclosure cover panel

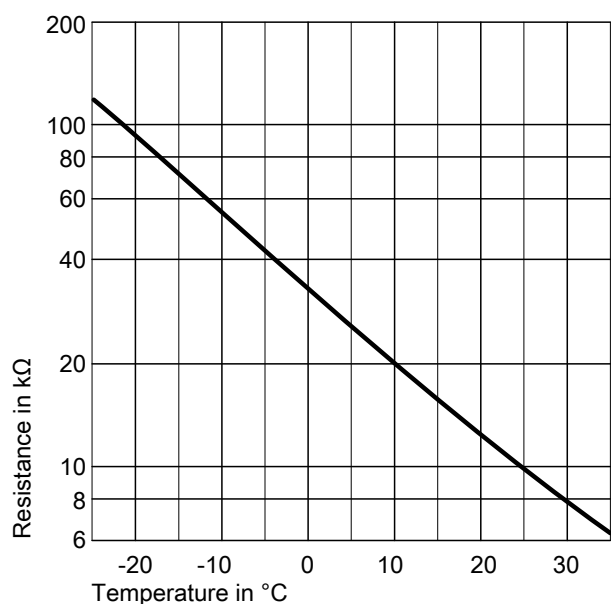

Fig. 25 Sensor type: NTC 10 kΩ

1. Disconnect plug "X3" from the control unit.
2. Test the resistance of the outside temperature sensor across terminals "X3.1" and "X3.2" on the disconnected plug and compare it with the curve.
3. If the results are very different from the curve, disconnect the wires from the sensor. Repeat the test directly on the sensor.
4. Depending on the test result, replace the lead or the outside temperature sensor.

Checking the cylinder temperature sensor

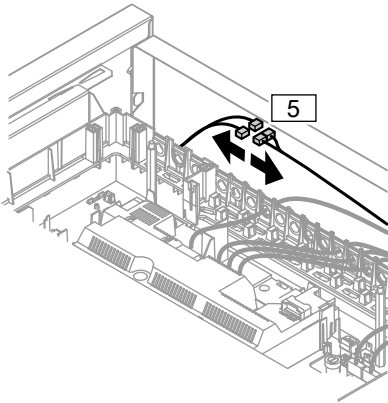

Fig. 26

1. **Cylinder temperature sensor**
Disconnect plug **5** and measure the resistance.
2. Check the sensor resistance. Compare the measured value with the curve.
3. In the event of severe deviation replace the sensor.

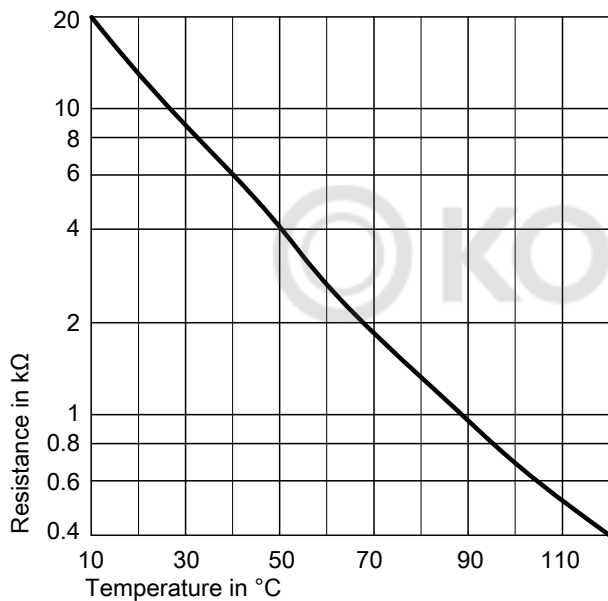

Fig. 27 Sensor type: NTC 10 kΩ

Checking boiler water temperature sensor

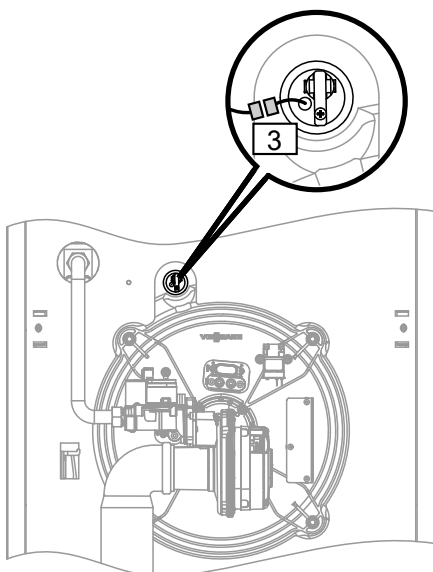

Fig. 28

1. **Boiler water temperature sensor**
Disconnect plug **3** and measure the resistance.
2. Check the sensor resistance. Compare the measured value with the curve.

Checking boiler water temperature sensor (cont.)

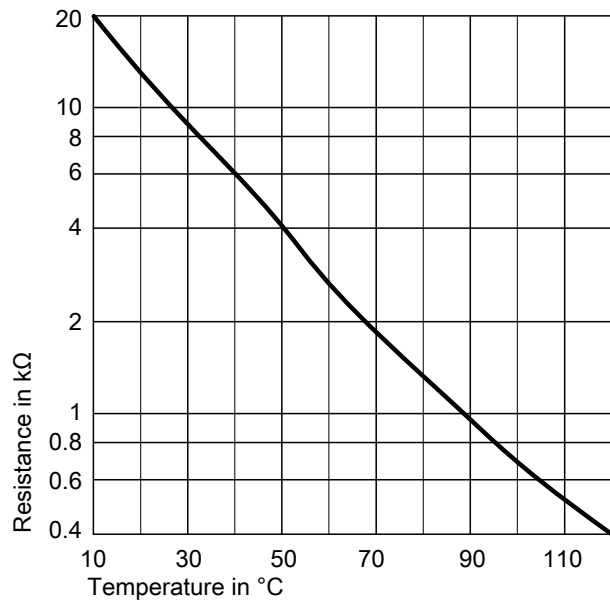

Fig. 29 Sensor type: NTC 10 kΩ

3. In the event of severe deviation replace the sensor.

Checking the flue gas temperature sensor

The flue gas temperature sensor locks out the boiler if the permissible flue gas temperature is exceeded. After the flue system has cooled down, press reset button **R** to cancel the lock.

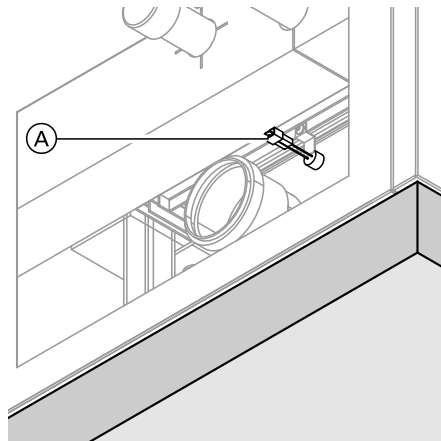

Fig. 30

1. Disconnect the leads from flue gas temperature sensor (A).

Checking the flue gas temperature sensor (cont.)

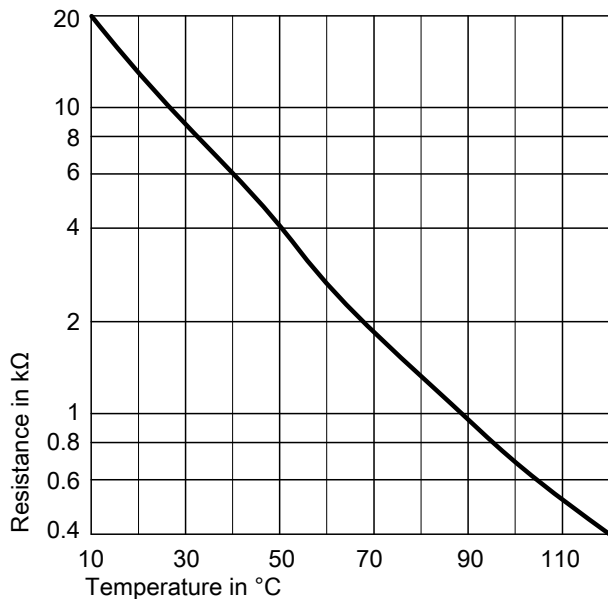

Fig. 31 Sensor type: NTC 10 kΩ

2. Check the sensor resistance. Compare the measured value with the curve.
3. In the event of severe deviation replace the sensor.

Fault during commissioning (fault A3)

During commissioning, the control unit checks for correct placement of the flue gas temperature sensor. If commissioning is terminated and fault message A3 is displayed:

1. Check whether the flue gas temperature sensor is correctly inserted. See previous diagram.
2. If necessary, correct the position of the flue gas temperature sensor or replace the faulty flue gas temperature sensor.
3. Press reset button **R** and repeat commissioning. The check is repeated until it is completed successfully.

Checking the temperature limiter

If the burner control unit cannot be reset after a fault shutdown although the boiler water temperature is below approx. 85 °C, check the following:

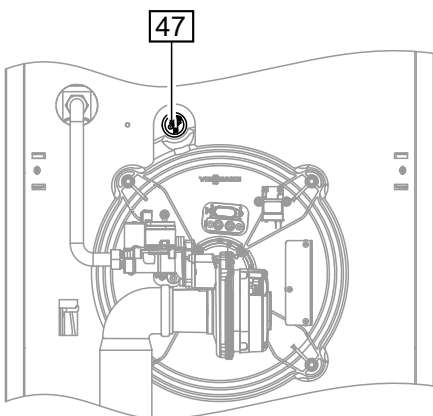

Fig. 32

1. Disconnect the leads from temperature limiter **47**.
2. Check continuity of the temperature limiter with a multimeter.
3. Remove faulty temperature limiter.
4. Coat the new temperature limiter with heat conducting paste and install it.
5. After commissioning, press reset button **R** on the control unit.

Checking the fuse

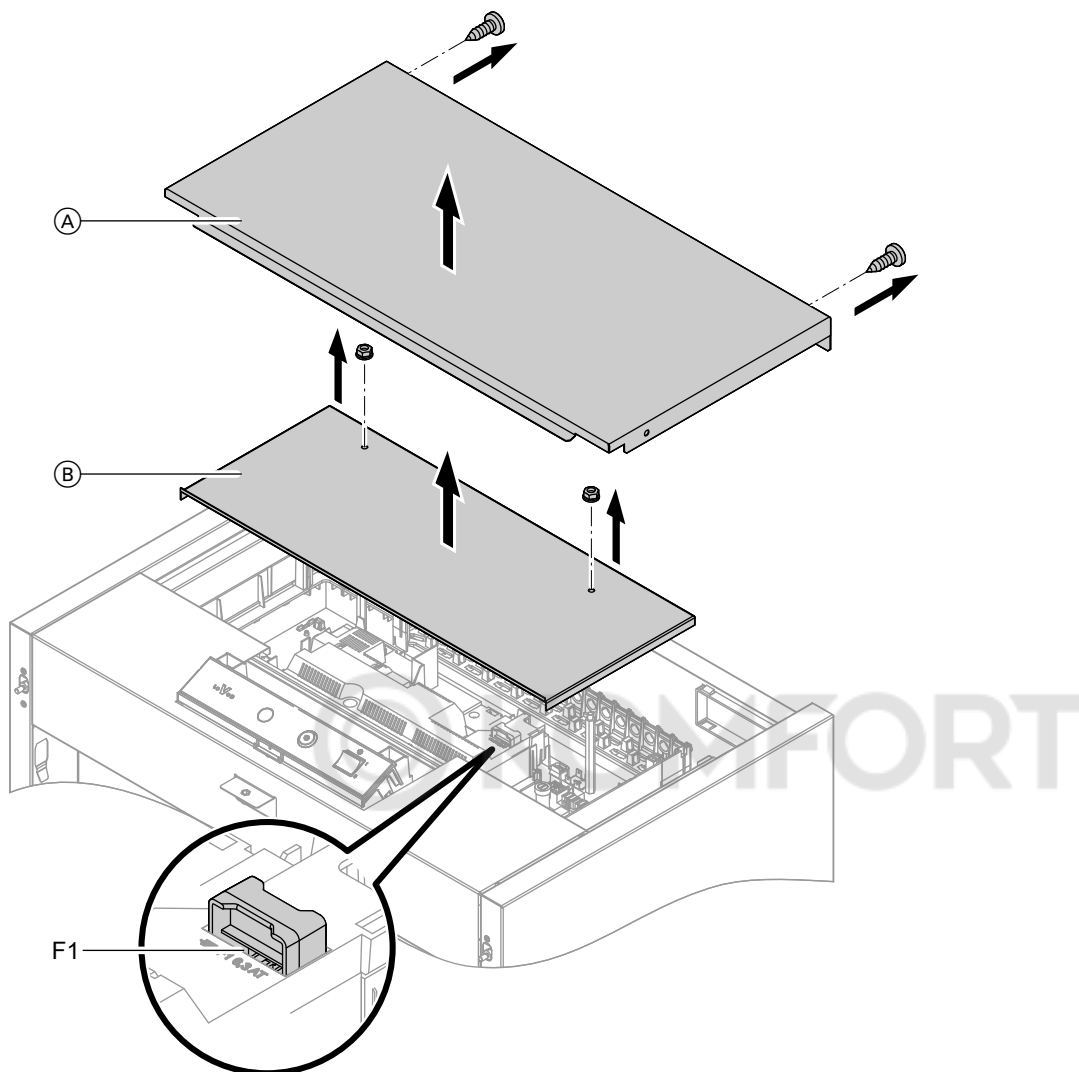

Fig. 33

1. Switch off the power supply.
2. Remove top panel (A) and cover (B).
3. Check fuse F1. Replace if necessary (see connection diagram figure 50 on page 90).



Danger



Incorrect or improperly fitted fuses can lead to an increased risk of fire.

- Insert fuses without using any force. Position fuses correctly.
- Only use structurally identical types with the specified response characteristics.

Mixer extension kit

Checking the setting of rotary selector S1

The rotary selector on the PCB of the extension kit defines the assignment to the relevant heating circuit.

Heating circuit	Rotary selector S1 setting
Heating circuit with mixer M2 (heating circuit 2)	2 
Heating circuit with mixer M3 (heating circuit 3)	4 

Mixer extension kit (cont.)

Checking the rotational direction of the mixer motor

After being switched on, the boiler implements a self-test. During this, the mixer is opened and closed again.

Note

The mixer motor can also be started via the actuator test (see chapter "Checking outputs").

Observe the rotational direction of the mixer motor during its self-test.

Then manually set the mixer back to "Open".

The flow temperature sensor must now capture a higher temperature. If the temperature drops, either the motor is turning in the wrong direction or the mixer insert is incorrectly fitted.



Mixer installation instructions

Changing the rotational direction of the mixer motor (if required)

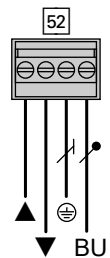

Fig. 34

1. Remove the upper casing cover of the extension kit.



Danger

An electric shock can be life-threatening. Before opening the boiler, disconnect it from the mains voltage, e.g. at the fuse or mains isolator.

2. At plug 52, swap the cores at terminals "▲" and "▼".
3. Refit the casing cover.

Check flow temperature sensor

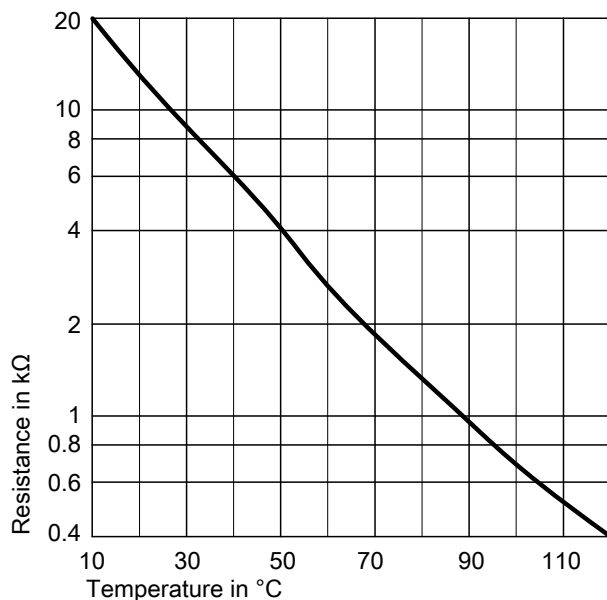

Fig. 35 Sensor type: NTC 10 kΩ

1. Disconnect plug 2 (flow temperature sensor).
2. Check the sensor resistance and compare it to the curve. In the event of severe deviation replace the sensor.

Checking the Vitotronic 200-H (accessories)

The Vitotronic 200-H is connected to the control unit via the LON cable. To test the connection, carry out a subscriber check at the boiler control unit (see page 29 onwards).

Weather-compensated control unit

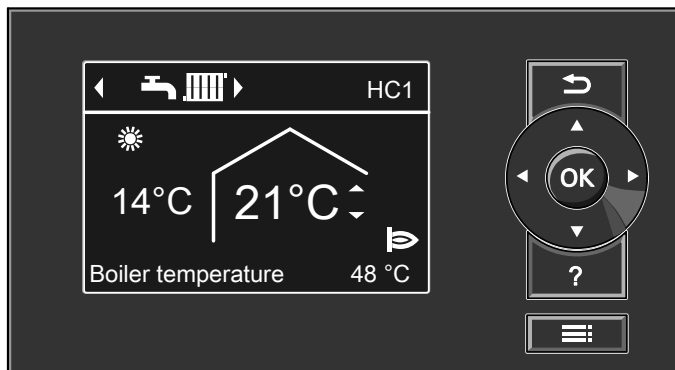

Fig. 36

Heating mode

The control unit determines a set boiler water temperature subject to outside temperature or room temperature (if a room temperature-dependent remote control is connected) and to the slope/level of the heating curve.

The determined set boiler water temperature is transferred to the burner control unit. From the set and actual boiler water temperatures, the burner control unit calculates the modulation level and regulates the burner accordingly.

The electronic temperature limiter inside the burner control unit limits the boiler water temperature.

DHW heating

The burner and the circulation pump for cylinder heating are started if the cylinder temperature during the cylinder enable time lies 2.5 K below the set cylinder temperature.

In the delivered condition, the set boiler water temperature is 20 K higher than the set cylinder temperature (adjustable via coding address "60"). If the actual DHW cylinder temperature exceeds the set cylinder temperature by 2.5 K, the burner shuts down and the circulation pump run-on time begins.

Boosting DHW heating

This function is activated by specifying a second set DHW temperature via parameter/coding address 58 in the "DHW" group and activating the fourth DHW time phase for DHW heating.

Heating is boosted during the periods selected in this time phase.

Connecting the Vitoconnect 100 connecting cable (accessories)

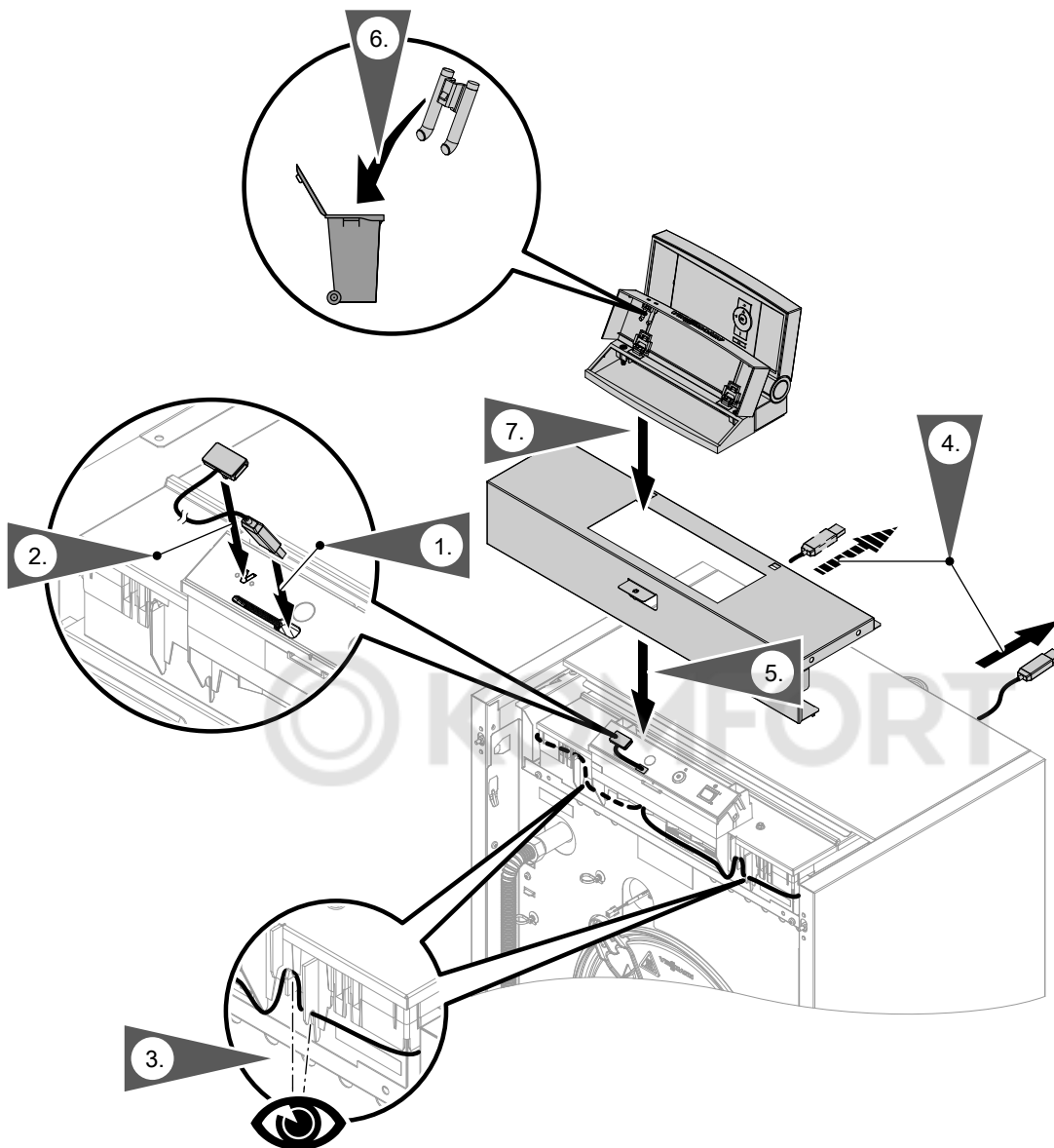



Fig. 37

Installing the Vitoconnect 100

 "Vitoconnect 100" installation and commissioning instructions

Internal extensions (accessories) (cont.)

Internal H2 extension

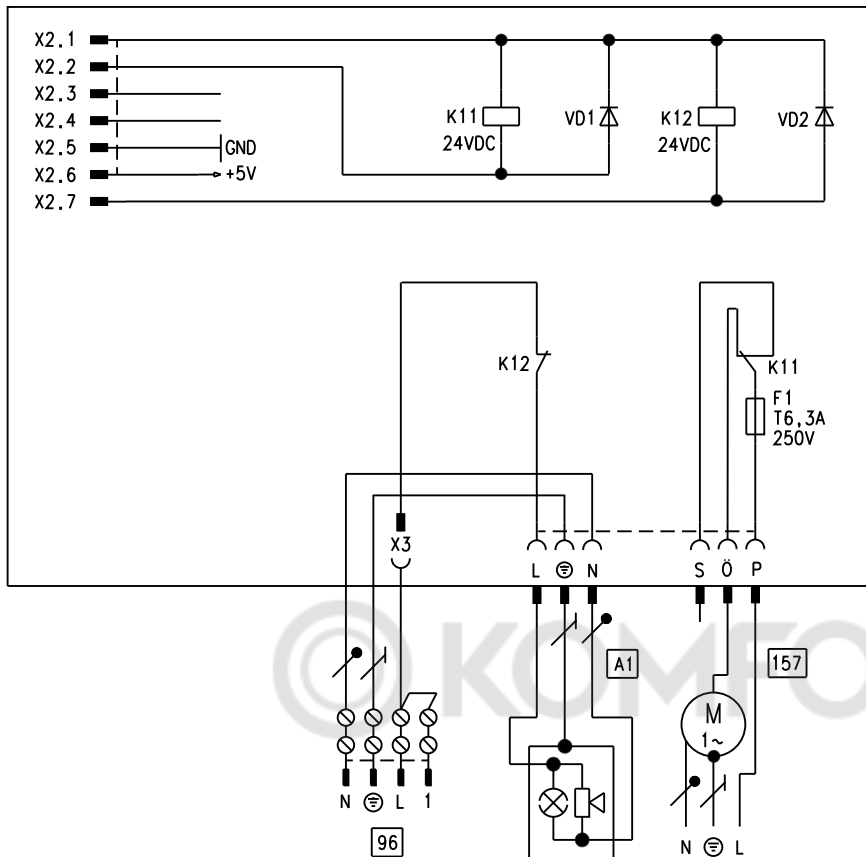

Fig. 39

The internal extension is integrated into the control unit enclosure.

- A central fault message facility can be connected to relay output "A1".
- An extractor fan can be switched off via connection 157 when the burner starts.

External extension (accessories)

EA1 extension

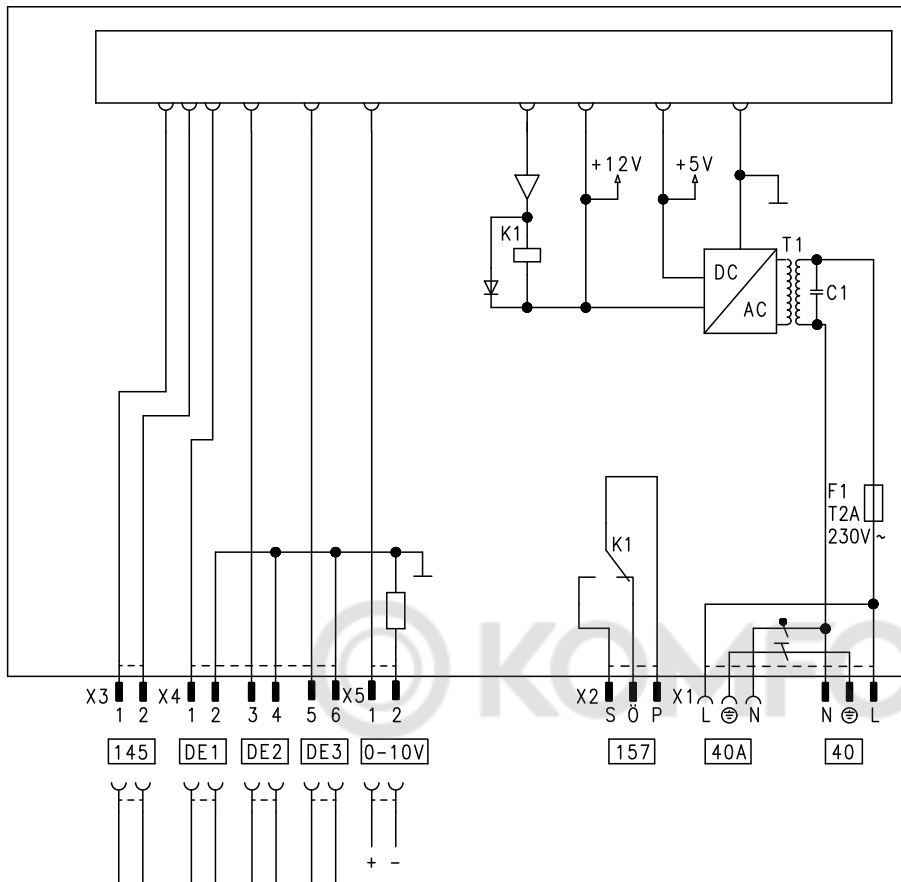

Fig. 40

- DE1 Digital input 1
- DE2 Digital input 2
- DE3 Digital input 3
- F1 Fuse
- 0 - 10 V 0 to 10 V input

- 40 Power supply
- 40 A Power supply for additional accessories
- 157 Central fault message/feed pump/DHW circulation pump (potential-free)
- 145 KM-BUS

Digital data inputs DE1 to DE3

The following functions can alternatively be connected:

- External operating program changeover for each heating circuit
- External blocking
- External blocking with fault message input
- External demand with minimum boiler water temperature
- Fault message input
- Brief operation of the DHW circulation pump

External contacts must be potential-free. When connecting external contacts, observe the requirements of protection class II: 8.0 mm air and creep path or 2.0 mm insulation thickness to live parts.

Input function assignment

The functions of the inputs are selected via the codes on the boiler control unit:

- DE1: Code 3A
- DE2: Code 3b
- DE3: Code 3C

Assigning the operating program changeover function to the heating circuits

The assignment of the operating program changeover function for the respective heating circuit is selected at the boiler control unit with code d8:

- Changeover via input DE1: Code d8:1
- Changeover via input DE2: Code d8:2
- Changeover via input DE3: Code d8:3

The effect of the operating program changeover is selected with code d5.

Set the duration of the changeover via code F2.

External extension (accessories) (cont.)**Effect of the "External blocking" function on the circulation pumps**

The effect on the relevant heating circuit pump is selected with code d6.
The effect on a circulation pump for cylinder heating is selected with code 5E.

Effect of the "External demand" function on the circulation pumps

The effect on the relevant heating circuit pump is selected with code d7.
The effect on a circulation pump for cylinder heating is selected with code 5F.

DHW circulation pump runtime for brief operation

The runtime is set in code 3d.

Analogue input 0 - 10 V

The 0 to 10 V hook-up provides an additional set boiler water temperature:

0 - 1 V \triangleq "No specification for set boiler water temperature"

1 V \triangleq Set value 10 °C

10 V \triangleq Set value 100 °C

Note

If the 0 - 10 V signal is not transmitted correctly, an isolating amplifier must be used for galvanic separation.

Output 157

One of the following functions can be connected to output 157:

- Feed pump to substation
- DHW circulation pump
- Fault message facility

Note on DHW circulation pumps

Connect DHW circulation pumps with standalone functions directly to the 230 V~ supply.

Function assignment

The function of output 157 is selected at the boiler control unit via code 36. See chapter "Code 2".

Control functions**External operating program changeover**

The "External operating program changeover" function is implemented via the EA1 extension. There are 3 inputs available at the EA1 extension (DE1 to DE3).

The function is selected via the following codes:

Operating program changeover	Code
Input DE1	3A:1
Input DE2	3b:1
Input DE3	3C:1

The heating program changeover function for the respective heating circuit is assigned at the boiler control unit via code d8:

Operating program changeover	Code
Changeover via input DE1	d8:1
Changeover via input DE2	d8:2
Changeover via input DE3	d8:3

You can select which direction the operating program changeover takes in coding address "d5":

Function description

Control functions (cont.)

Operating program changeover	Code
Changeover towards "Permanently reduced" or "Permanent standby mode" (according to the selected set value)	d5:0
Changeover towards "Continuous heating mode"	d5:1

The duration of the operating program changeover can be adjusted in coding address "F2":

Operating program changeover	Code
No operating program changeover	F2:0
Duration of the operating program changeover 1 to 12 h	F2:1 to F2:12

The operating program changeover stays enabled for as long as the contact remains closed, but at least as long as the duration selected in coding address "F2".

External blocking

When the contact is closed, the burner is switched off. The heating circuit pump and (if installed) circulation pump for cylinder heating are switched according to the set codes.

The external connection is switched via a floating contact.

Connection options:

- Plug 96
- EA1 extension (accessories)

Plug 96

- The function is selected via code "4b:2" in the "**General**"/1 group.
- The effect on the circulation pump for cylinder heating is selected with code "5E" "**DHW**"/3.
- The effect on the relevant heating circuit pump is selected with code "d6" "**Heating circuit**".

EA1 extension

The functions "External blocking" and "External blocking with fault message input" are implemented via the EA1 extension. There are 3 inputs available at the EA1 extension (DE1 to DE3).

The function is selected via the following codes:

External blocking	Code
Input DE1	3A:3
Input DE2	3b:3
Input DE3	3C:3

External blocking and fault message input	Code
Input DE1	3A:4
Input DE2	3b:4
Input DE3	3C:4

Control functions (cont.)

External demand

When the contact is closed, burner operation is load-dependent. The boiler water is heated to the set value selected in coding address "9b" in the **"General"/1** group. The boiler water temperature is limited by this set value and by the electronic maximum limit (coding address "06" in the **"Boiler"/2** group).

The external connection is switched via a floating contact.

Connection options:

- Plug 96
- EA1 extension (accessories)

Plug 96

- The function is selected via code 4b:1 in the **"General"/1** group.
- The effect on the circulation pump for cylinder heating is selected with code 5F in the **"DHW"/3** group.
- The effect on the relevant heating circuit pump is selected with code "d7" in the **"Heating circuit"** group.

EA1 extension

The "External demand" function is implemented via the EA1 extension. There are 3 inputs available at the EA1 extension (DE1 to DE3).

The function is selected via the following codes:

External demand	Code
Input DE1	3A:2
Input DE2	3b:2
Input DE3	3C:2

- The effect on the circulation pump for cylinder heating is selected with code 5F in the **"DHW"/3** group.
- The effect on the relevant heating circuit pump is selected with code "d7" in the **"Heating circuit"** group.
- The minimum set boiler water temperature for external demand is selected in coding address "9b".

Screed drying

The screed drying function enables screeds to be dried. For this, observe the screed manufacturer's instructions.

When screed drying is enabled, the heating circuit pump for the heating circuit with mixer starts and the flow temperature is maintained in accordance with the selected profile. On completion (30 days), the heating circuit with mixer is regulated automatically according to the set parameters.

Observe EN 1264. The report to be provided by the heating contractor must contain the following details regarding heat-up:

- Heat-up data with the relevant flow temperatures
- Max. flow temperature achieved
- Operating state and outside temperature during handover

The various temperature profiles are adjustable via coding address "F1".

The function continues after a power failure or after the control unit has been switched off. "Heating and DHW" is started if screed drying is finished or if code "F1:0" is set manually.

Temperature profile 1: (to EN 1264-4) code "F1:1"

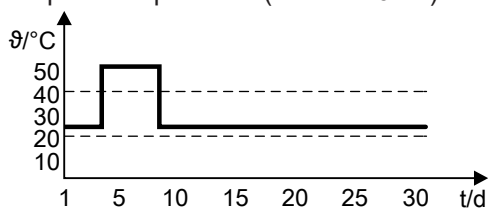

Fig. 41

Function description

Control functions (cont.)

Temperature profile 2: (acc. to ZV parquet and flooring technology) code "F1:2"

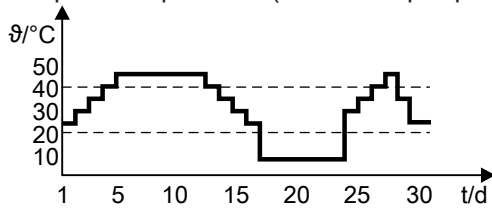

Fig. 42

Temperature profile 3 (to ÖNORM): Code "F1:3"

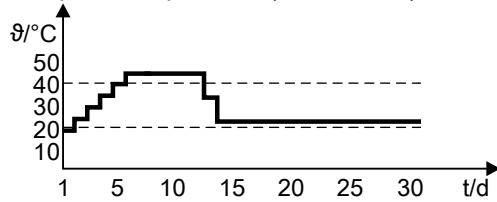

Fig. 43

Temperature profile 4: Code "F1:4"

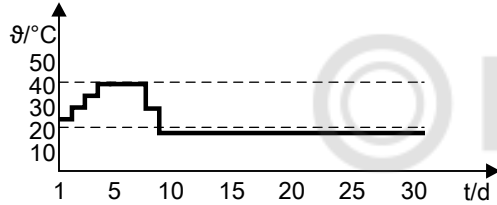

Fig. 44

Temperature profile 5: Code "F1:5"

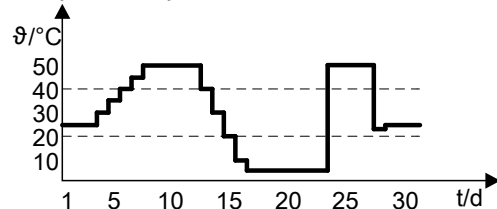

Fig. 45

Temperature profile 6: Code "F1:6"

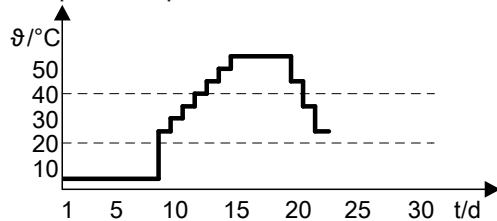

Fig. 46

Temperature profile 7: Code "F1:15"

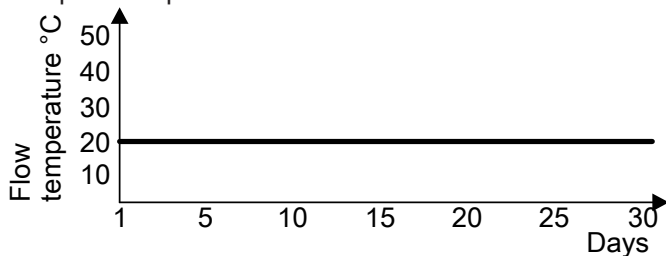

Fig. 47

Control functions (cont.)

Raising the reduced room temperature

During operation at reduced room temperature, the reduced set room temperature can be automatically raised subject to the outside temperature. The temperature is raised in accordance with the selected heating curve, and no higher than the standard set room temperature.

The outside temperature limits for the start and end of the temperature raising can be adjusted via coding addresses "F8" and "F9".

Example using the settings in the delivered condition

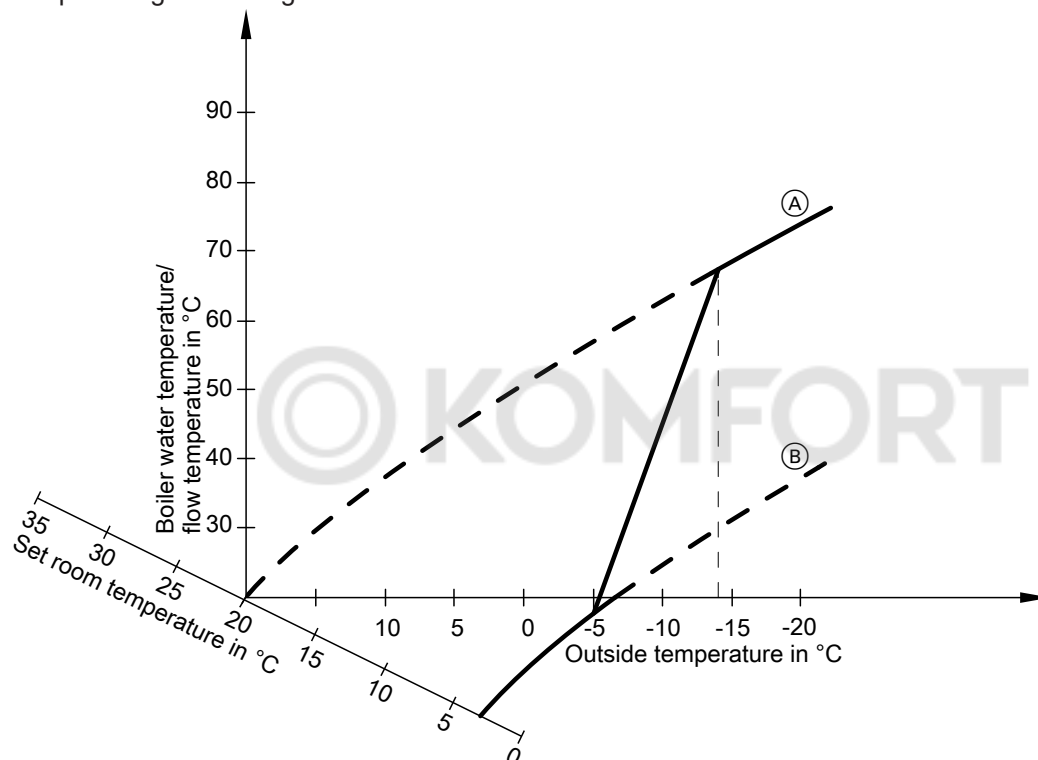

Fig. 48

- Ⓐ Heating curve for operation at standard room temperature
- Ⓑ Heating curve for operation at reduced room temperature

Reducing the heat-up time

During the transition from operation with reduced room temperature to operation with standard room temperature, the boiler water or flow temperature is raised in accordance with the selected heating curve. The boiler water or flow temperature increase can be automatically raised.

The value and duration of the additional increase of the set boiler water or flow temperature is selected in coding addresses "FA" and "Fb".

Function description

Control functions (cont.)

Example using the settings in the delivered condition

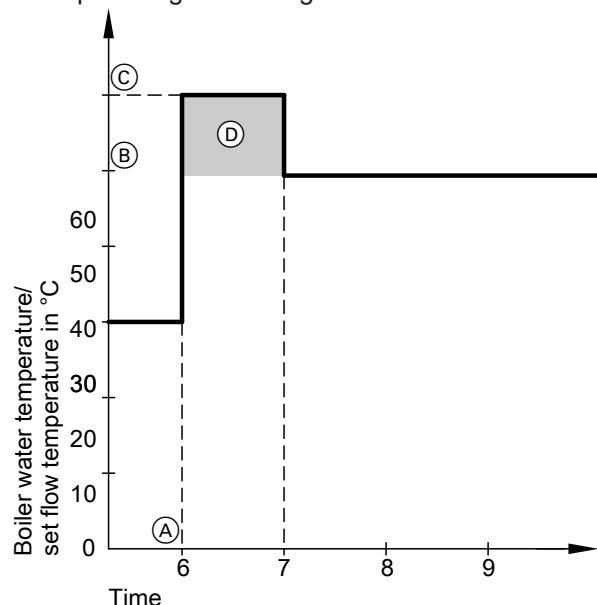

Fig. 49

- (A) Start of operation at standard room temperature
- (B) Set boiler water or flow temperature in accordance with the selected heating curve
- (C) Set boiler water or flow temperature in accordance with coding address "FA":
50 °C + 20 % = 60 °C
- (D) Duration of operation with raised set boiler water or flow temperature in accordance with coding address "Fb":
60 min

Assigning heating circuits to the remote control

The heating circuit assignment must be configured when commissioning the Vitotrol.

Heating circuit	Vitotrol configuration	
	200-A/200-RF	300-A
The remote control affects the heating circuit without mixer A1.	H 1	HC 1
The remote control affects the heating circuit with mixer M2.	H 2	HC 2
The remote control affects the heating circuit with mixer M3.	H 3	HC 3

- One heating circuit can be assigned to the Vitotrol 200A/200 RF.
- Up to 3 heating circuits can be assigned to the Vitotrol 300-A.
- Up to 2 remote control units can be connected to the control unit.
- If the heating circuit allocation is later cancelled, reset parameter/coding address A0 for this heating circuit to 0 (fault message bC, bd, bE).

Electronic combustion control unit

The electronic combustion controller utilises the physical correlation between the level of the ionisation current and the air ratio λ . The maximum ionisation current is achieved at an air ratio of 1 for all gas qualities.

The ionisation signal is evaluated by the combustion controller and the air ratio is adjusted to a value between $\lambda=1.24$ and 1.44. This range provides for an optimum combustion quality. Thereafter, the electronic gas valve regulates the required gas volume subject to the prevailing gas quality.

Electronic combustion control unit (cont.)

To check the combustion quality, the CO₂ content or the O₂ content of the flue gas is measured. The prevailing air ratio is determined with the measured values. The relationship between the CO₂ or O₂ content and air ratio λ is illustrated in the following table.

Air ratio λ – CO₂/O₂ content

Air ratio λ	O ₂ content (%)	CO ₂ content (%) for natural gas E	CO ₂ content (%) for natural gas LL	CO ₂ content (%) for LPG P
1.20	3.8	9.6	9.2	11.3
1.24	4.4	9.2	9.1	10.9
1.27	4.9	9.0	8.9	10.6
1.30	5.3	8.7	8.6	10.3
1.34	5.7	8.5	8.4	10.0
1.37	6.1	8.3	8.2	9.8
1.40	6.5	8.1	8.0	9.6
1.44	6.9	7.8	7.7	9.3
1.48	7.3	7.6	7.5	9.0

To achieve an optimum combustion control, the system regularly carries out an automatic self-calibration; also after a power failure (shutdown). For this, the combustion is briefly regulated to max. ionisation current (corresponding to air ratio $\lambda=1$). Automatic calibration is carried out shortly after the burner start and lasts approx. 5 s. During calibration, higher than normal CO emissions may occur briefly.

Internal connection diagram

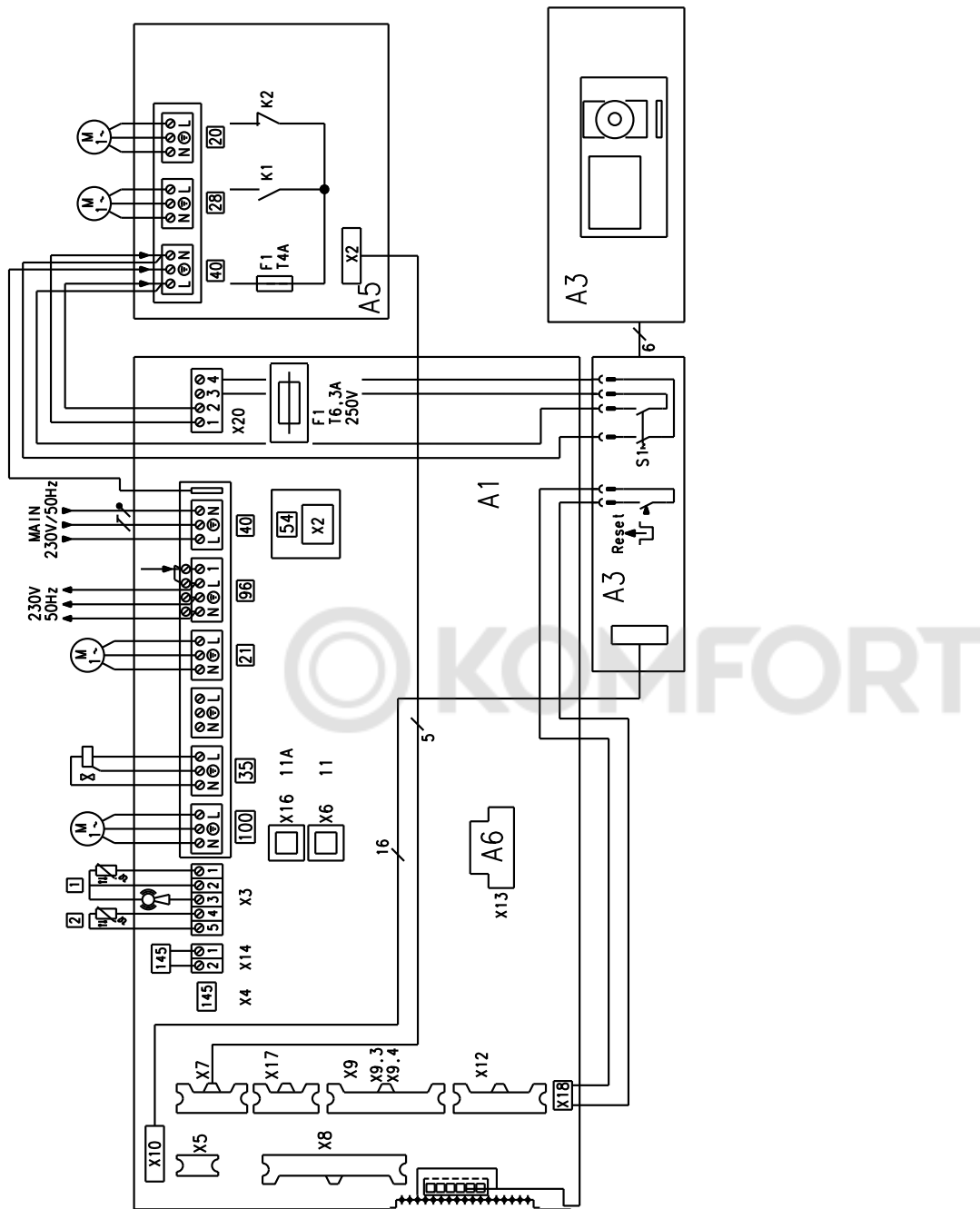

Fig. 50

- 20 Heating circuit pump A1
- 28 DHW circulation pump
- A1 Main PCB
- A3 Programming unit Vitotronic 200 KW6A
- A5 Connection extension SA104A10
- A6 Coding card
- A7 Adaptor
- A8 LON communication module
- A9 Internal extension SA100B10 (accessories)
- H1 or H2

Internal connection diagram (cont.)

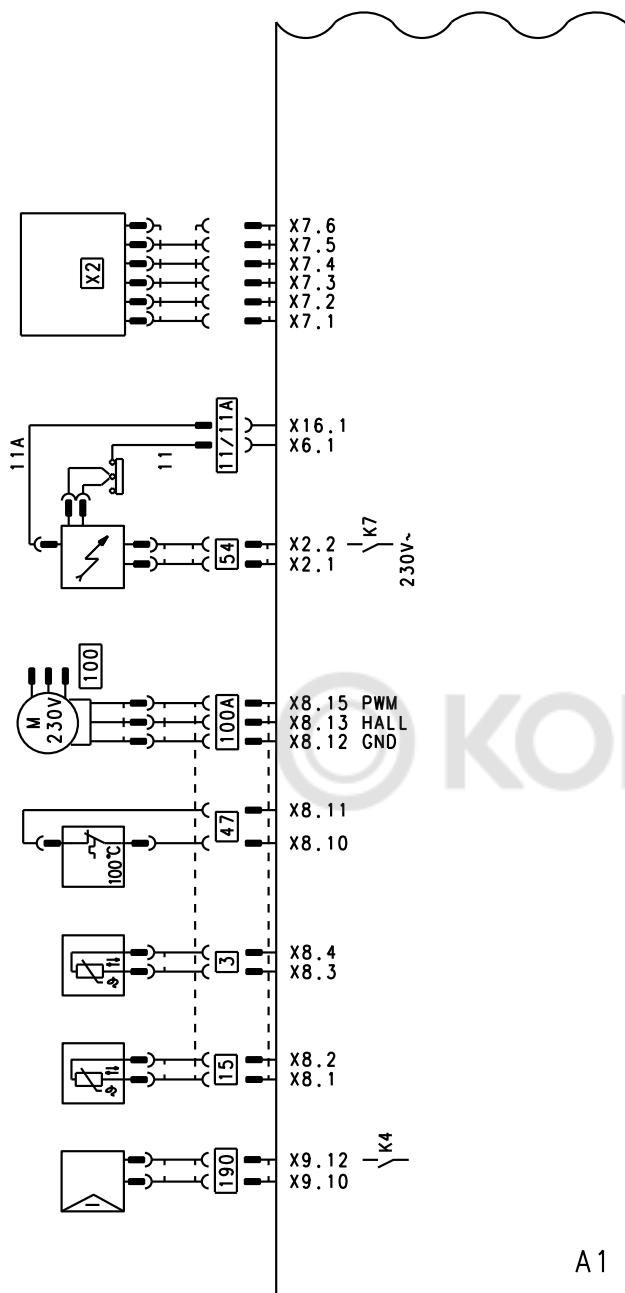

Fig. 51

- | | | | |
|--------|---------------------------------|------|----------------------|
| A1 | Main PCB | 54 | Ignition unit |
| 3 | Boiler water temperature sensor | 100A | Fan motor control |
| 11/11A | Ionisation monitoring | 190 | Modulation coil |
| 15 | Flue gas temperature sensor | X2 | Connection extension |
| 47 | Temperature limiter | | |

External connection diagram

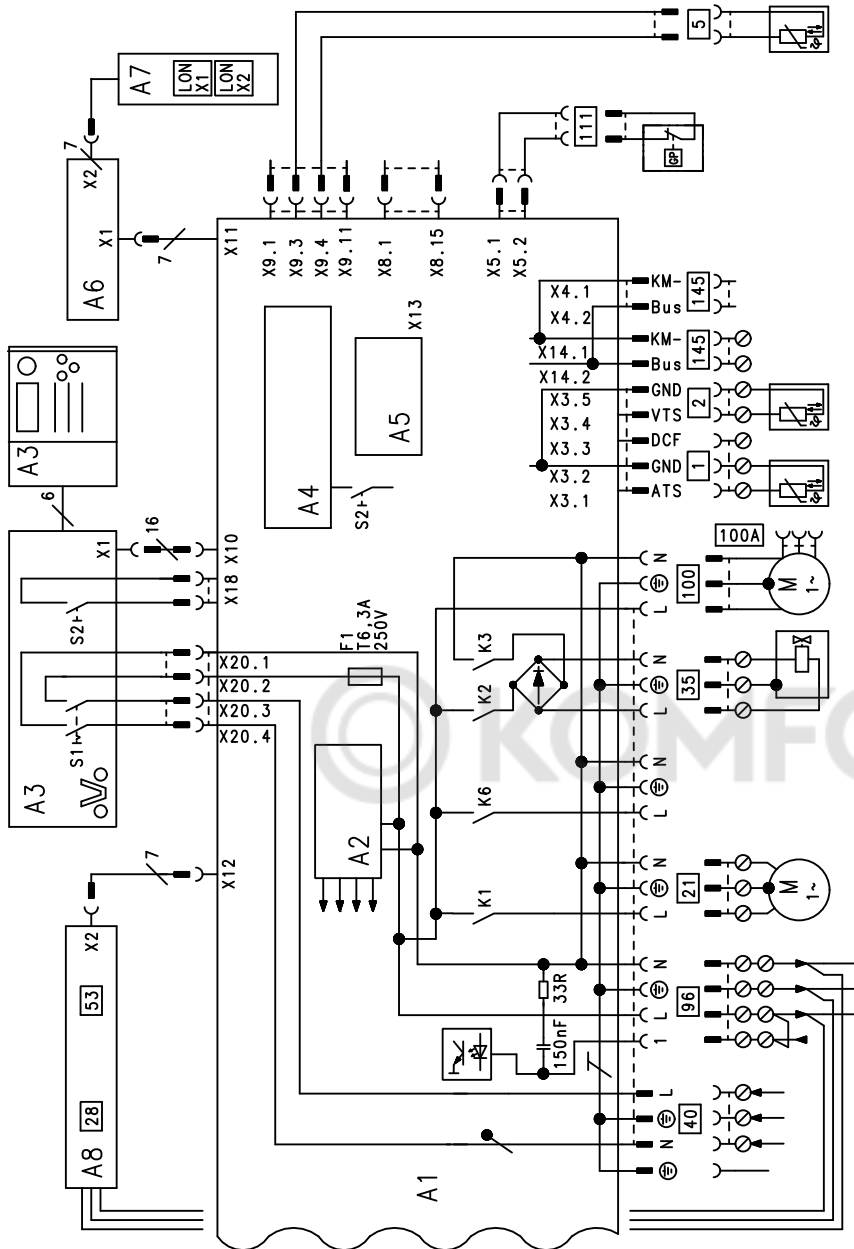

Fig. 52

- | | | | |
|----|---|-----|---------------------------------------|
| A1 | Main PCB | 2 | Flow temperature sensor |
| A2 | Power supply unit | 5 | Cylinder temperature sensor |
| A3 | Programming unit/Optolink | 21 | Circulation pump for cylinder heating |
| A4 | Burner control unit | 35 | Solenoid valve |
| A5 | Coding card | 40 | Power supply |
| A6 | Connection adaptor | 96 | Network accessories |
| A7 | LON communication module (Vitotronic 200) | | External blocking |
| A8 | Internal H1 extension (accessories) | | External demand |
| S1 | ON/OFF switch | 100 | Fan motor |
| S2 | Reset button | 145 | KM-BUS |
| 1 | Outside temperature sensor | | |

Requirements

Water quality requirements

Note

Observing the following requirements is necessary to safeguard your warranty rights.

The warranty excludes damage due to corrosion and scaling.

Total heating output kW	Total alkaline earths mol/m ³	Total hardness °dH
≤ 50	≤ 3.0	≤ 16.8
> 50 to ≤ 200	≤ 2.0	≤ 11.2
> 200 to ≤ 600	≤ 1.5	≤ 8.4
> 600	< 0.02	< 0.11

The standard values assume the following:

- The total volume of fill and top-up water will not exceed three times the water content of the heating system during its service life.
- The specific system volume is less than 20 l/kW heating output. In multi boiler systems, apply the output of the smallest boiler.
- All measures to prevent corrosion on the water side in accordance with VDI 2035 Part 2 have been implemented.

Soften the fill and top-up water in heating systems operating under the following conditions:

- The total of alkaline earths in the fill and top-up water exceeds the standard value.
- Higher fill and top-up water volumes are expected.
- The specific system volume is greater than 20 l/kW heating output. In multi boiler systems, apply the output of the smallest boiler.
- In systems > 50 kW, install a water meter to capture the amount of fill and top-up water. Enter the volume of fill water and the water hardness into the boiler maintenance checklists.
- For systems with a specific system volume greater than 20 l/kW heating output, apply the requirements of the next higher category of total heating output (in accordance with the table). In multi boiler systems, apply the output of the smallest boiler. In the case of severe overshoot (> 50 l/kW), soften the water down to a total of alkaline earths of ≤ 0.02 mol/m³.

Prevention of damage due to scaling

Prevent excessive scale build-up (calcium carbonate) on the heating surfaces. For heating systems with operating temperatures up to 100 °C, VDI Guideline 2035 Part 1 "Prevention of damage in water heating installations - Scale formation in domestic hot water supply installations and water heating installations" applies together with the following standard values. See the explanations in the original text of the Guideline.

Operating information:

- During expansion or repair work, only drain the pipe-work sections necessary.
- Check, clean and activate filters, dirt traps and other blow-down or separating facilities in the heating water circuit frequently after commissioning and in new installations. Thereafter check and maintain these facilities as required, depending on the type of water treatment applied (e.g. water softening).
- **No further** steps are required during commissioning if you fill the heating system **with fully softened water**.
If the heating system is charged, **not with fully softened water**, but with water that meets the requirements in the above table, **also observe the following during commissioning**:
 - Commission the system step by step with a high heating water flow rate, starting with the lowest boiler output. This prevents localised concentration of limescale deposits on the boiler heating surfaces.
 - In multi boiler systems, start all boilers simultaneously to prevent the entire limescale deposit settling in the heat exchanger of just one boiler.
 - Where water treatment is required, treat even the first fill of the heating system prior to commissioning. This also applies to any subsequent filling, e.g. when adding top-up water or after a repair, or for any system expansion.

The build-up of limescale deposits on the heating surfaces will be minimised if these instructions are followed.

Failure to observe the requirements of VDI Guideline 2035 can result in damaging limescale deposits. In such cases, the service life of the installed boilers will, most often, already have been reduced. Removing the limescale deposits is one option for restoring operational viability.

Requirements (cont.)

This measure must be carried out by a qualified contractor. Inspect the heating system for possible damage prior to returning it into use. It is essential that incorrect operating parameters are corrected to prevent renewed excessive scaling.

Prevention of damage due to corrosion on the water side

The corrosion resistance of ferrous materials on the heating water side of heating systems and heat generators depends on the absence of oxygen in the heating water. The oxygen introduced into the heating system with the first fill and subsequent top-ups reacts with the system materials without causing damage.

The characteristic blackening of the water after a certain time in operation indicates that there is no more free oxygen present. In accordance with the technical rules and in particular VDI Guideline 2035-2, we recommend that the heating system is designed and operated so that a constant ingress of oxygen into the heating water is prevented.

During operation, oxygen can enter due to:

- Open vented expansion vessels with flow through
- Negative pressure in the system
- Permeable components

Correctly sized sealed unvented systems operating at the correct pressure, e.g. systems with expansion vessel, offer good protection against the ingress of airborne oxygen. Under all operating conditions and at all points in the heating system, including the intake side of the pump, the pressure must be higher than atmospheric pressure. Check the pre-charge pressure of the expansion vessel at least during the annual service. Avoid the use of permeable components, e.g. permeable plastic pipes in underfloor heating systems. Provide system separation if such components are nevertheless used. This system separation must separate the water flowing through the plastic pipes from other heating circuits, e.g. from the boiler, by the provision of a corrosion resistant heat exchanger.

No further anti-corrosion measures are required for sealed unvented hot water heating systems, subject to the above points being observed. However, take additional precautions where there is a risk of oxygen ingress, for example by adding oxygen binder sodium sulphite (5 to 10 mg/l into the excess). The pH value of the heating water should be between 8.2 and 9.5. Different conditions apply to systems that contain aluminium components.

Where chemicals are used as part of the corrosion protection, we recommend that the manufacturer of the chemicals issues a certificate of suitability of the additives with regard to the boiler materials and the materials of other components. Please refer questions regarding water treatment to an appropriate contractor.

Further details can be found in VDI Guideline 2035-2 and EN 14868.

© KOMFORT

Settings and test values

Settings and test values	on by	Set value	Commissioning	Maintenance/ service
Static pressure	<i>mbar</i> <i>kPa</i>	≤ 57.5 ≤ 5.75		
Supply pressure (flow pressure)				
<input type="checkbox"/> for natural gas E	<i>mbar</i> <i>kPa</i>	17.4-25 1.74-2.5		
<input type="checkbox"/> for natural gas LL	<i>mbar</i> <i>kPa</i>	17.4-25 1.74-2.5		
<input type="checkbox"/> for LPG	<i>mbar</i> <i>kPa</i>	42.5-57.5 4.25-5.75		
<i>Tick the gas type</i>				
Carbon dioxide content CO₂				
For natural gas E and LL				
▪ At lower heating output	<i>% by vol.</i>	7.7-9.2		
▪ At upper heating output	<i>% by vol.</i>	7.7-9.2		
For LPG				
▪ At lower heating output	<i>% by vol.</i>	9.3-10.9		
▪ At upper heating output	<i>% by vol.</i>	9.3-10.9		
Oxygen content O₂				
▪ At lower heating output	<i>% by vol.</i>	4.4-6.9		
▪ At upper heating output	<i>% by vol.</i>	4.4-6.9		
Carbon monoxide content CO				
▪ At lower heating output	<i>ppm</i>	< 60		
▪ At upper heating output	<i>ppm</i>	< 60		

Specification

Gas boiler, types B and C

Rated heating output range							
$T_F/T_R = 50/30 \text{ °C}$	kW	2.6 to 13	2.6 to 19	5.2 to 26	7 to 35	12 to 45	12 to 60
$T_F/T_R = 80/60 \text{ °C}$	kW	2.4 to 12.0	2.4 to 17.5	4.7 to 24.0	6.3 to 32.3	10.9 to 41.6	10.9 to 55.5
Rated heat input	kW	2.5 to 16.7	2.5 to 17.9	4.9 to 24.5	6.6 to 33	11.3 to 42.5	11.3 to 56.6
Product ID	CE-0085BN0570						
Category		II _{2N3P}	II _{2N3P}	II _{2N3P}	II _{2N3P}	II _{2N3P}	II _{2N3P}
Gas supply pressure	mbar	20	20	20	20	20	20
Max. permiss. gas supply pressure^{*2}	mbar	50	50	50	50	50	50
Supply values							
Relative to the max. load with							
▪ Natural gas E	m ³ /h	1.30	1.90	2.61	3.52	4.47	5.95
▪ Natural gas LL	m ³ /h	1.51	2.20	3.04	4.10	5.19	6.91
▪ LPG	kg/h	0.95	1.39	1.93	2.60	3.34	4.45
Power consumption (in the delivered condition)	W	30	30	37	56	68	115
Rated voltage	230 V						
Rated frequency	50 Hz						
Rated current	6 A						
Protection class	I						
Backup fuse	Max. 16 A						
Permissible ambient temperature							
▪ Operation	0 to +40 °C						
▪ Storage and transport	-20 to +65 °C						
Electronic temperature limiter setting	90 °C						
Temperature limiter setting	110 °C (fixed)						
Energy efficiency class	A						

Note

The supply values are only for reference (e.g. in the gas contract application) or for a supplementary, rough estimate to check the volumetric settings. Due to factory settings, the gas pressure must not be altered from these values. Reference: 15 °C, 1013 mbar

Shutdown and disposal

Final decommissioning and disposal

Viessmann products can be recycled. Components and substances from the system are not part of ordinary domestic waste.

For decommissioning, isolate the system from the power supply and allow components to cool down where appropriate.
All components must be disposed of correctly.



Declaration of conformity

We, Viessmann Climate Solutions SE, D-35108 Allendorf, declare as sole responsible body that the named product complies with the European directives and supplementary national requirements in terms of its design and operational characteristics.

Using the serial number, the Declaration of Conformity can be found on the following website:
www.viessmann.co.uk/eu-conformity

Manufacturer's certificate according to the 1st BImSchV [Germany]

We, Viessmann Werke GmbH & Co. KG, D-35107 Allendorf, confirm that the product **Vitocrossal 300** complies with the NO_x limits specified by the 1st BImSchV paragraph 6 [Germany].

Allendorf, 1 February 2018

Viessmann Werke GmbH & Co. KG

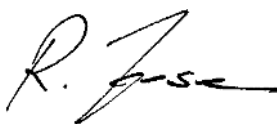

Authorised signatory Reiner Jansen
Head of Strategic Quality Management



Keyword index

A	
Acknowledging a fault display.....	57
Actuator test.....	55
B	
Boiler water requirements.....	93
Boiler water temperature sensor.....	73
Boosting DHW heating.....	78
Brief scans.....	54
Burner	
– Installation.....	26
– Removal.....	19
Burner gauze assembly.....	20
C	
Checking functions.....	55
Coding level 1	
– Boiler.....	33
– Calling up.....	32
– DHW.....	34
– General.....	32
– Heating circuit.....	36
– Solar.....	34
Coding level 2	
– Boiler.....	44
– Calling up.....	39
– DHW.....	44
– General.....	39
– Heating circuit.....	49
Combustion chamber, cleaning.....	22
Combustion controller.....	88
Combustion quality, checking.....	27
Condensate drain system.....	22
Connection diagram	
– External.....	92
– Internal.....	90
Control unit	
– Connection to LON.....	29
– Matching.....	28
Cylinder temperature sensor.....	73
D	
Date, setting.....	13
Disposal.....	98
E	
Electronic combustion controller.....	88
Expansion vessel.....	24
Extension	
– EA1.....	82
– Internal H1.....	80
– Internal H2.....	81
Extension kit for heating circuit with mixer	76
External blocking.....	84
External demand.....	85
F	
Fault codes.....	57
Fault during commissioning.....	75
Fault history.....	57
Fault manager.....	30
Fault memory.....	57
Fault message call-up.....	57
Faults.....	57
Fill and top-up water.....	25
Fill water.....	12
Flue gas temperature sensor.....	74
Front panel	
– Mounting.....	31
– Removal.....	14
Function descriptions.....	78
Function sequence.....	15
Fuse.....	76
G	
Gaskets, checking.....	24
Gas solenoid valve.....	16
Gas supply pressure.....	17
Gas type.....	13
– Converting.....	15
H	
Heating circuit assignment.....	88
Heating curve.....	28
Heating curve level.....	29
Heating curve slope.....	29
Heating output setting.....	17
Heating surfaces, cleaning.....	22
Heat-up time.....	87
I	
Ignition electrodes.....	21
Intended use.....	9
Ionisation electrode.....	21
L	
Language, changing.....	12
Leak test, balanced flue system.....	18
LON.....	29
– Fault monitoring.....	30
– Subscriber check.....	30
– Subscriber number setting.....	29
LON communication module.....	29
M	
Manufacturer's certificate	99
Mixer, checking.....	25
Mixer open/closed.....	77
N	
Neutralising system.....	22, 23
O	
Operating conditions, checking.....	54
Operating data, checking.....	54
Operating program changeover.....	83
Outside temperature sensor.....	72





KOMFORT

Viessmann Climate Solutions SE
35108 Allendorf / Germany
Telephone: +49 6452 70-0
Fax: +49 6452 70-2780
www.viessmann.com



Viessmann Limited
Hortonwood 30, Telford
Shropshire, TF1 7YP, GB
Telephone: +44 1952 675000
Fax: +44 1952 675040
E-mail: info-uk@viessmann.com

6192251 Subject to technical modifications.