



# COLLETTORI CON VALVOLE A SFERA COLLETTORI CON VALVOLE A SFERA

## Serie NINO

### Descrizione / Description

Collettori "NINO" con attacchi 1/2"x16 e valvola a sfera.

Manifold "NINO" with connections 1/2"x16 and ball valve.

### Funzione / Function

I collettori di distribuzione "NINO" sono generalmente utilizzati nelle reti di distribuzione di acqua calda e fredda. Grazie alla loro configurazione permettono l'alimentazione in parallelo delle utenze per acqua calda e/o fredda riducendo al minimo le perdite di carico.

I collettori sono prodotti in conformità alle normative in materia e sono certificati relativamente alla composizione chimica dei materiali impiegati ed a livello dimensionale.

The distribution manifolds "NINO" are typically used for hot and cold water distribution.

Due to the configuration they may be used to distribute cold/hot water in parallel reducing at minimum the pressure drop. The manifolds are produced according to the relevant rules and are certified for material chemical composition and dimensional request.

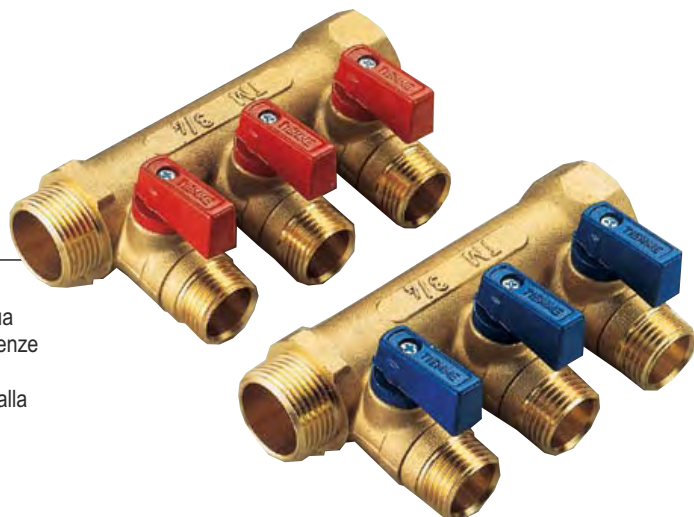

### Caratteristiche Tecniche

Temperatura max di esercizio: 110°C  
 Temperatura min di esercizio: -20°C  
 Pressione max di esercizio: 16 bar  
 Filettature : maschio UNI ISO 7/1 R conica  
 femmina UNI ISO 7/1 Rp cilindrica

### Technical Features

Maximum temperature: 110°C  
 Minimum temperature: -20°C  
 Maximum operating pressure: 16 bar  
 Threads: male UNI ISO 7/1 R conical  
 female UNI ISO 7/1 Rp parallel

### Dimensioni / Dimensions

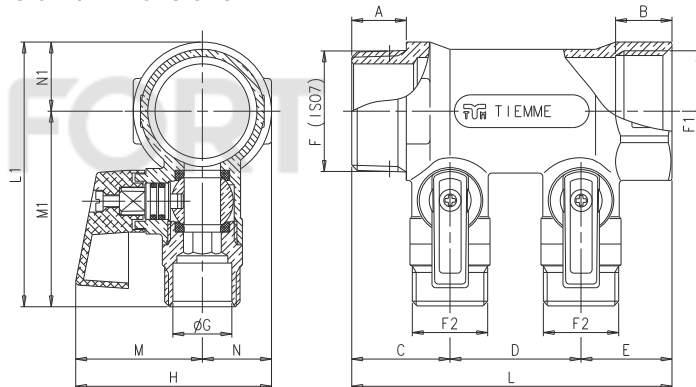

Art. 18...CP

Descrizione	Materiale	Trattamento
Corpo	Ottone CW617N - EN12165	-
Sfera	Ottone CW617N - EN12164	Cromata
Stelo	Ottone CW617N - EN12164	-
O-rings	Gomma nitrilica NBR	-
Guarnizioni laterali	P.T.F.E.	-
Leva	Alluminio	Verniciata rossa o blu
Vite	Acciaio	-

Description	Material	Treatment
Body	CW617N-EN12165 brass	-
Ball	CW617N-EN12164 brass	Chrome plated
Stem	CW617N-EN12164 brass	-
O-rings	Nitrile Rubber NBR	-
Side washers	P.T.F.E.	-
Handle	Aluminium	Painted red or blue
Screw	Steel	-

### Certificazioni Certifications



Codice/Code	Size	A	B	C	D	E	F	F1	F2	G	H	L	L1	M	M1	N	N1
1822G160402 1820002	3/4"	16,5	16,5	28,5	36,0	27,0	3/4"	3/4"	1/2"	16,2	51,0	91,5	66,5	35,0	50,5	16,0	16,0
1823G160403 1820001	3/4"	16,5	16,5	28,5	36,0	27,0	3/4"	3/4"	1/2"	16,2	51,0	127,5	66,5	35,0	50,5	16,0	16,0
1824G160404 1820016	3/4"	16,5	16,5	28,5	36,0	27,0	3/4"	3/4"	1/2"	16,2	51,0	163,5	66,5	35,0	50,5	16,0	16,0
1832G160402 1820006	1"	17,0	17,0	29,0	36,0	27,0	1"	1"	1/2"	16,2	54,0	92,0	72,5	35,0	53,5	19,0	19,0
1833G160403 1820005	1"	17,0	17,0	29,0	36,0	27,0	1"	1"	1/2"	16,2	54,0	128,0	72,5	35,0	53,5	19,0	19,0
1822G140402CP 1820009	3/4"	16,5	16,5	28,5	36,0	27,0	3/4"	3/4"	1/2"	14,0	51,0	91,5	66,5	35,0	50,5	16,0	16,0
1823G140403CP 1820008	3/4"	16,5	16,5	28,5	36,0	27,0	3/4"	3/4"	1/2"	14,0	51,0	127,5	66,5	35,0	50,5	16,0	16,0
1832G140402CP 1820014	1"	17,0	17,0	29,0	36,0	27,0	1"	1"	1/2"	14,0	54,0	92,0	72,5	35,0	53,5	19,0	19,0
1833G140403CP 1820013	1"	17,0	17,0	29,0	36,0	27,0	1"	1"	1/2"	14,0	54,0	128,0	72,5	35,0	53,5	19,0	19,0



Diagrammi portata/perdita di carico  
Flow/pressure drop diagrams

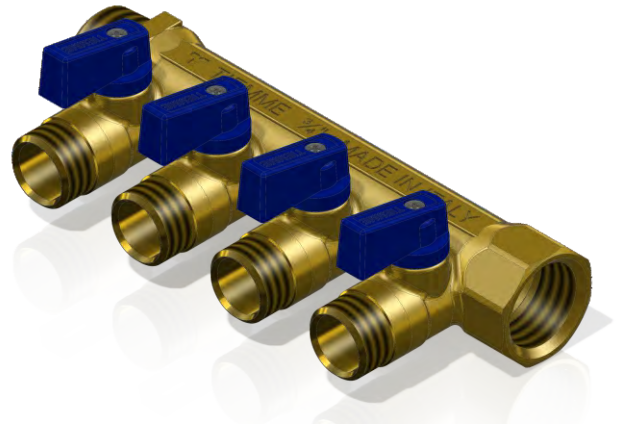
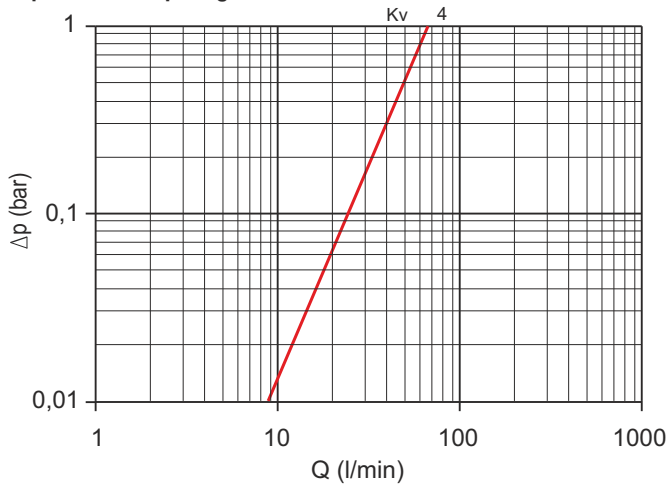

Guida alle connessioni  
Fitting guide

Art. 1822-1823-1824-1832-1833

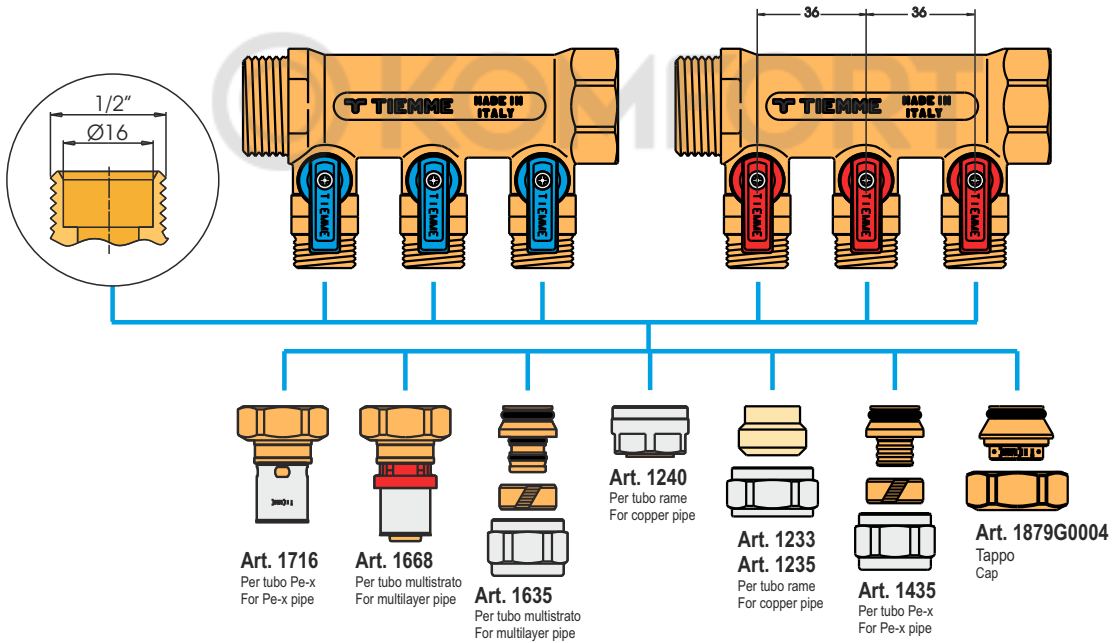

Art. 1822CP-1823CP-1832CP-1833CP

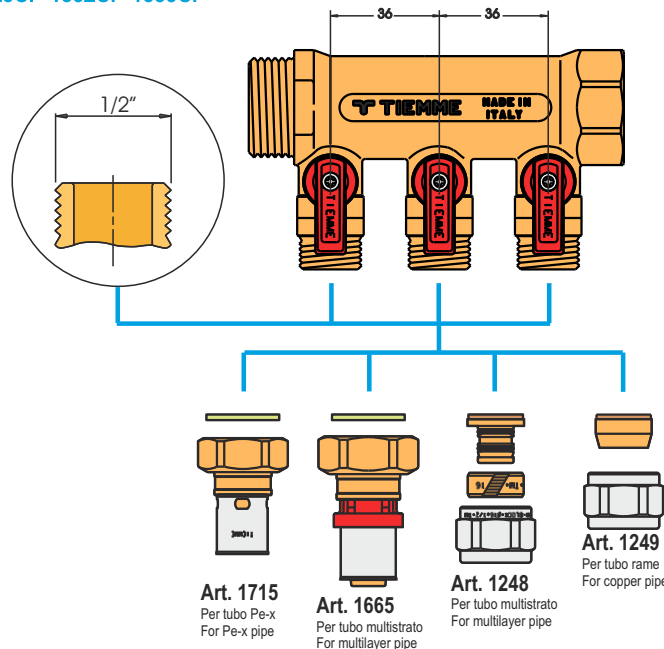



**Cassette utilizzabili**  
**Boxes used**

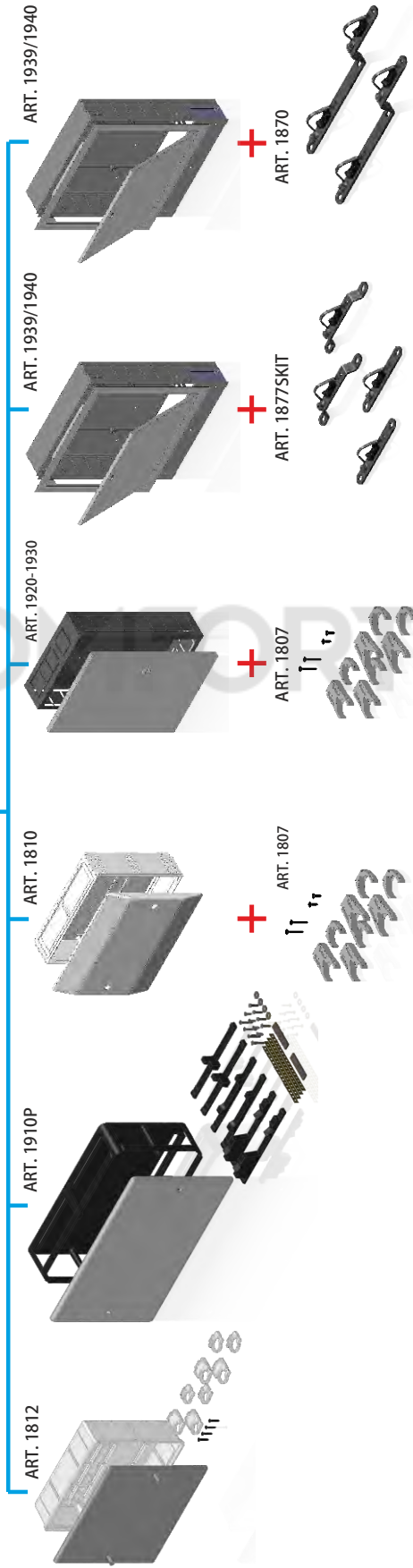
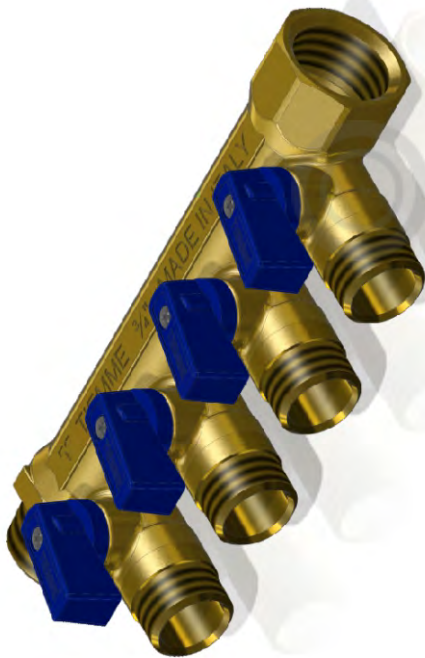

**TIEMME Raccorderie S.p.A.**  
Via Cavallera 6/A (Loc. Barco) - 25045 Castegnato (Bs) - Italy  
Tel +39 030 2142211 R.A. - Fax +39 030 2142206  
info@tiemme.com - www.tiemme.com